



Valla®



VALLA 55 - TRX MOBILE TRACKED CRANE Max Capacity 5,5 t.



ENGINE: Diesel HP 54,5 - 4 cylinders, water cooled.

TRANSMISSION: Automatic (hydrostatic). Max speed 4 km/h.

ELECTRIC SYSTEM: 12 V.

CRANE FRAME: Fabricated from preformed and welded steel plate with built-in counterweight.

TRACKED UNDERCARRIAGE: On rubberized steel tracks. Two fixed hydraulic motors.

BOOM: Fabricated from preformed and welded steel plate with 3 hydraulic telescoping sections fitted with adjustable nylon wear pads.

HYDRAULIC SYSTEM: Powered by gear pump through 2 valves distributor lever operated, one for raising/lowering, one for extending/retracting the boom. Fitted with safety valves. Max pressure 200 bar.

DRIVER'S OVERHEAD GUARD: Steel frame with metal checker plate and full visibility.

WEIGHT: Kg. 5.650~.

OPTIONAL EXTRAS: L.M.I. (electronic Load Moment Indicator), hydraulic winch, hydraulic chain hoist, man bucket, remote control, metal/glass enclosed cab, manual jib extension, LPG conversion.

The crane complies with following international standards:

- I.S.P.E.S.L.
- DIN 15018(1,3) - 15019 (1) Class H2 B3
- ANSI - 1994
- 98/37/CE
- 89/336/CEE

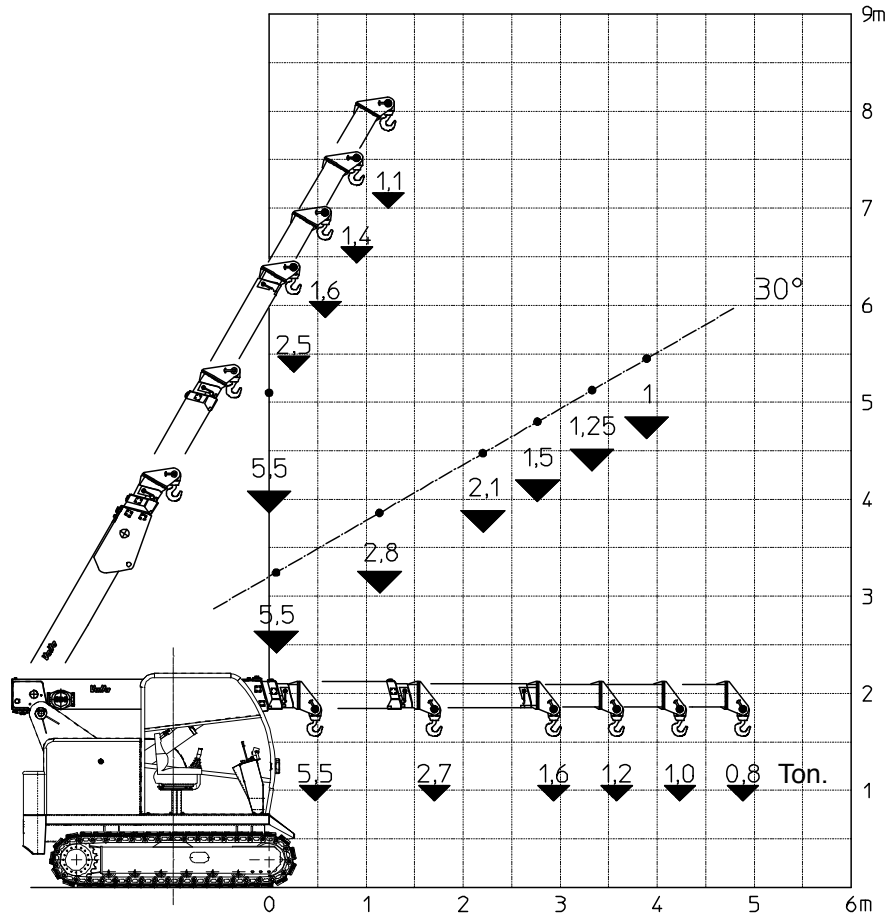

MODEL 55 - TRX

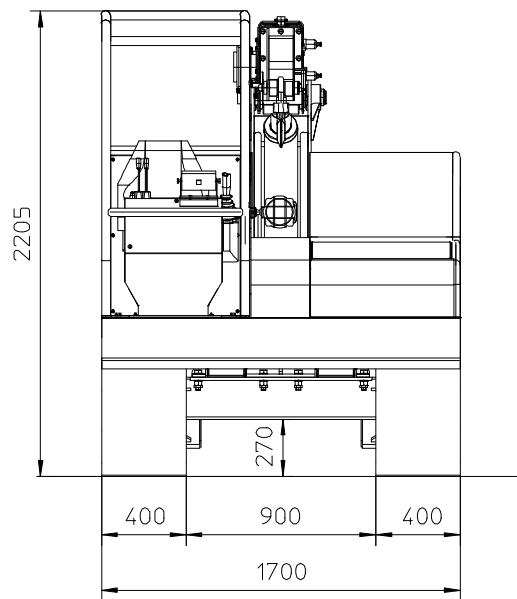
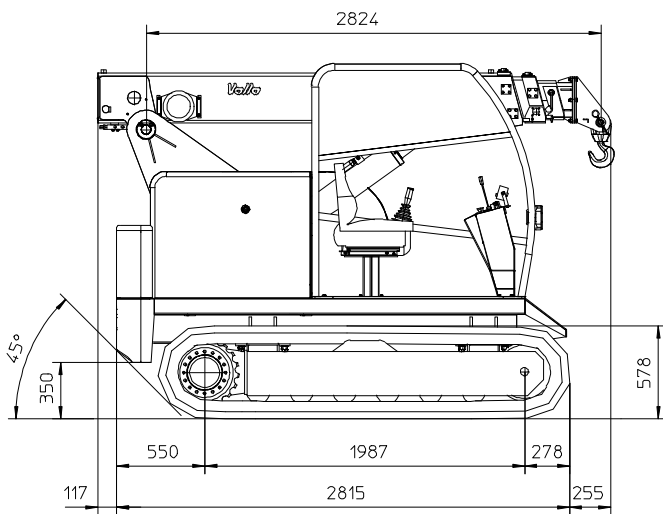

mm

