

# TUKAN MULTIPURPOSE AND SHIPYARD

DOUBLE JIB LEVEL LUFFING CRANES

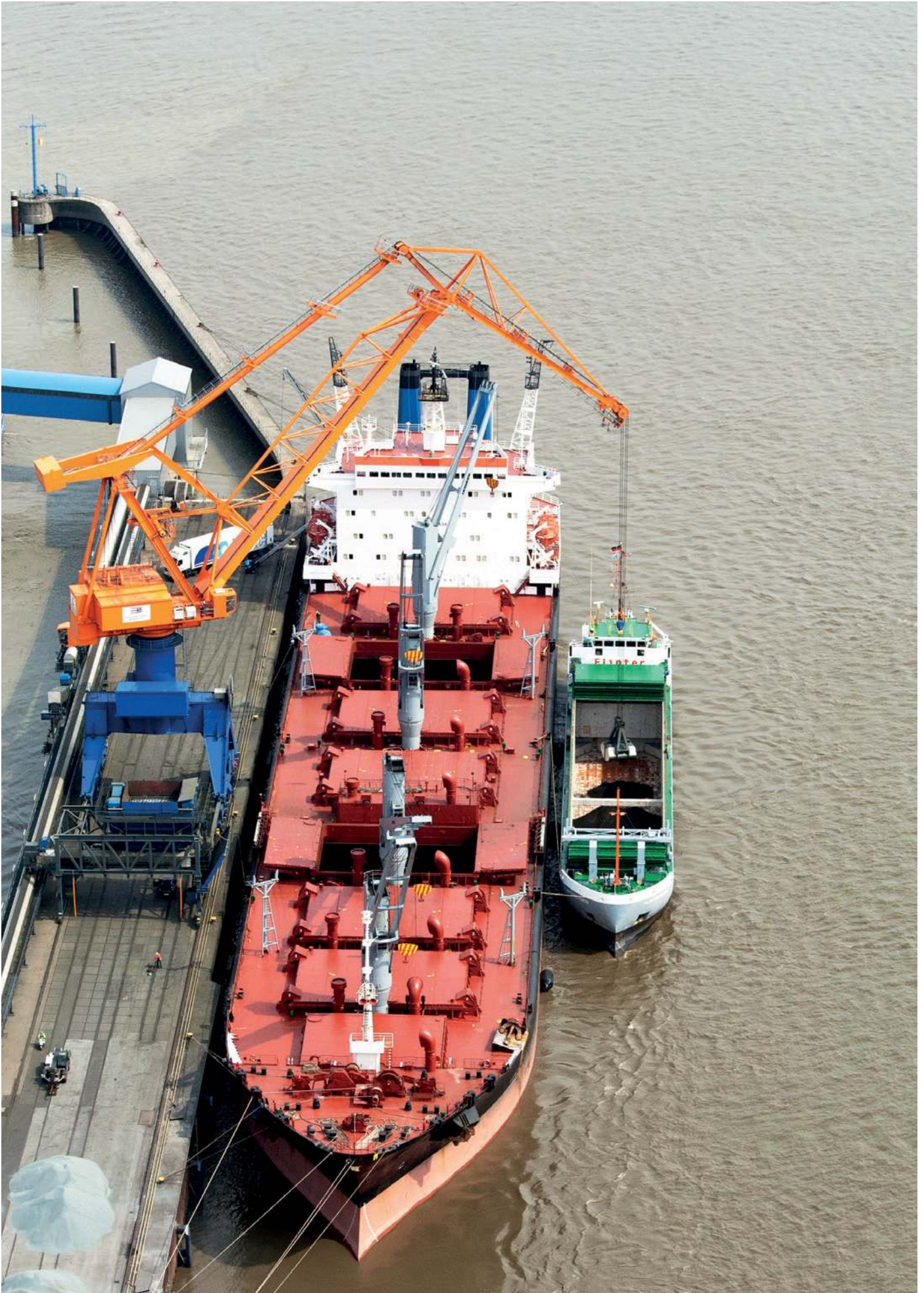





↑  
A Tukan Multipurpose crane in use for transshipping at Brunsbüttel port, Germany



# TUKAN. THE EFFICIENT ALL-ROUNDER.

A PERFECT  
CRANE SYSTEM FOR  
MULTIPURPOSE  
TRANS-SHIPMENT.



↑  
Loading parts for wind turbines in tandem operation

The world's ports handle a flow of commodities that is rapidly growing with the expansion of global trade. As ships become larger and lay times shorter, more goods need to be turned over. A big challenge both for those who manage trans-shipment and for shipbuilders. In this setting, cranes with versatile uses are highly efficient tools.

Choose the perfect crane for your operating conditions and have Ardelt configure and customise ideal solutions from a wealth of proven high-quality assemblies.

Ardelt offers, for example, the Tukan Multipurpose, a highly efficient universal crane for handling bulk goods, containers and general cargo, or alternatively for heavier or specialized handling the Tukan Shipyard, designed especially for precision with durable strength.

The Tukan range has proven its worth in all climate zones by working perfectly around the clock and meeting the most diverse requirements. To this day Ardelt has delivered more than 2,700 of these cranes worldwide.

## → INFO

**Where do the best dockside and shipyard cranes excel? What counts?**

### → **Essentially this is**

- maximum handling capacity
- versatility permitting full utilisation
- high profitability
- low energy consumption

### → **... and in detail**

- a perfect match for operating conditions on a specific site
- high efficiency by maximising output on a minimum of quay length
- safe and efficient handling of bulk goods, containers and general cargo
- maximum reliability and availability
- minimum environmental impact with very few emissions and high energy efficiency
- minimum life cycle costs as the crane is easy to maintain and has a long service life
- first-rate aftersales service and speedy spare parts supply

These are all standard characteristics of the Tukan and give you XL efficiency and XL performance.

# THE ENVIRONMENT-FRIENDLY LOW-ENERGY CRANE.

EFFICIENT AND POWERFUL ON QUAYS  
AND IN SHIPYARDS.

FULLY ELECTRIC AND  
RELIABLE TO GIVE YOU  
MAXIMUM PERFORMANCE.

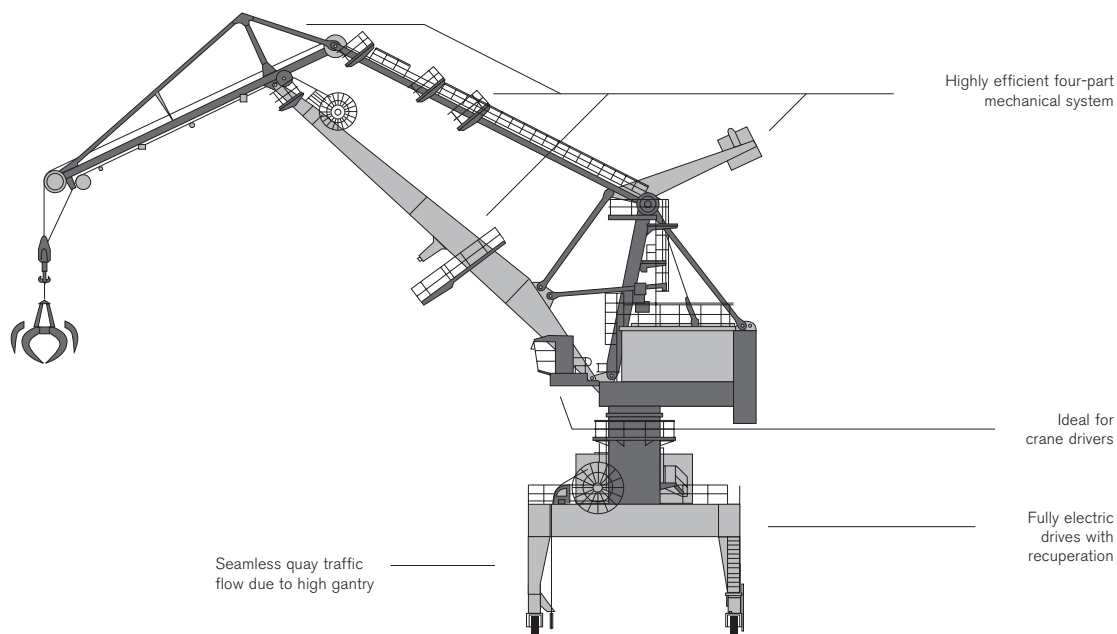

↑ Tukan: double jib level luffing principle and fully electric drives

Maximum efficiency with minimum maintenance: a typical feature of the Tukan. How do we do it? Quite simply through the most effective combination of the double jib principle with fully electric drives, which benefits operators and crane drivers alike.

Direct electric drives throughout minimise the crane's environmental impact. It is emission free, economical and much more efficient thanks to its energy management system. At the same time, you save on operating and life cycle costs compared with diesel or electrohydraulic drives.

Another feature which conserves energy is movable dead weight compensation in the link systems of Ardel cranes. Here the luffing gear consumes less power than single jib cranes without movable counterweights and thus saves operating costs.



↑ Handling coal with a grab



↑  
Power supply

Power recovered during lowering/braking may be used to feed electric devices operating at the same time or can be fed back into the mains supply. This remarkable performance relies on advanced converters and energy recovery in conjunction with highly efficient motors and reliable control systems. The low level of power consumption is thus further reduced, and savings of up to 30% can be achieved compared with fully electric systems where energy is not recovered. Diesel-driven slewing cranes can need up to 500% more power.

Another advantage is that a fully electric crane is very quiet, and its drives generate less noise than any other comparable system.

Fully electric drives cost much less when it comes to maintenance and repairs there is no need to pay for expensive hydraulic or diesel oil and the regular replacement of seals and flexible pressure tubing. The cables of an electric crane, by contrast, give you a full service life. The extremely efficient components Ardel uses for drives guarantee

additional advantages such as a long life, maximum availability and best performance.

Intelligent management thus makes the energy balance of fully electric Ardel drives clearly superior to that of other driving mechanisms. Where the local mains is at the same time fed from regenerative sources such as the wind or sun, the fully electric drives of Tukan cranes can save even more energy and thus make supplies more sustainable.

#### → INFO

##### Tukan characteristics:

- extremely energy-efficient: optimised mechanical design, intelligent energy management system with recovery
- minimum environmental impact: no waste gas, little noise, no need for hydraulic/diesel oil
- major cost savings: efficient components, low maintenance/repair/life cycle costs, minimum energy consumption



# WHO WOULDN'T WANT TO SET A NEW STANDARD? ARDELT'S **DOUBLE JIB PRINCIPLE.**

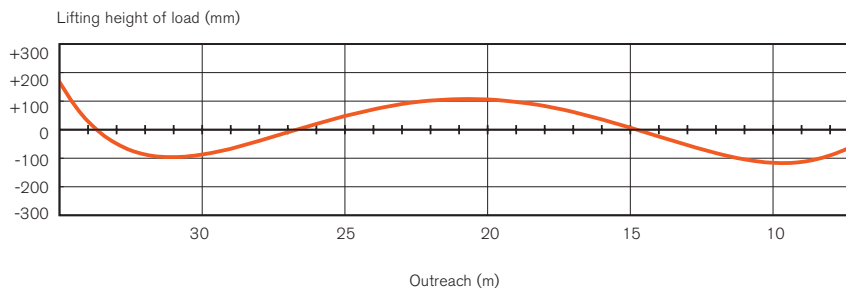
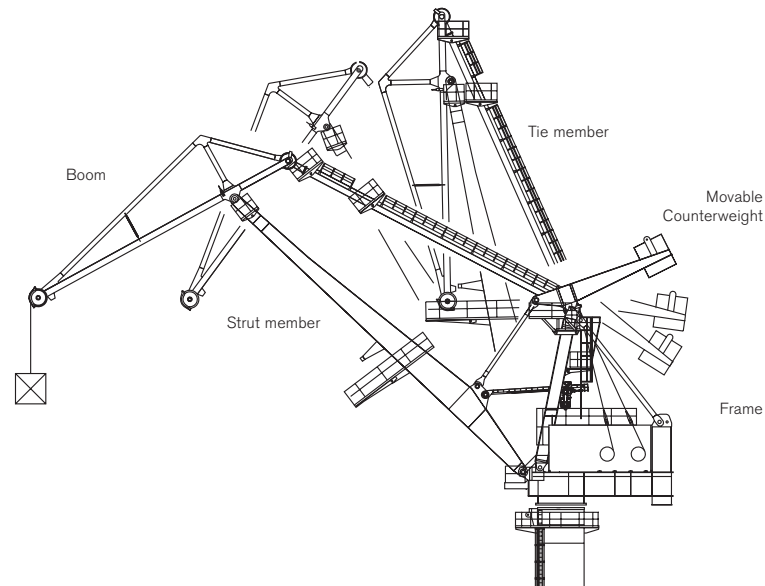

↑  
Jib system – horizontal load path

Double jibs for level luffing cranes were invented in 1932. Since then Ardel has built thousands of these cranes, improved and optimised the system and become the world's market leader for double jib level luffing cranes. Their booms with integrated movable counterweights have a number of essential advantages.

The boom/jib arrangement incorporates four parts: a stationary frame, tie member, strut member and movable boom. This specific geometry makes sure that the ideal horizontal load path is covered

by purely mechanical means if the outreach changes. The ingenious double jib system prevents the undesired lifting or lowering of loads even if rope guides are only elementary, which greatly improves handling capacity and productivity.

The characteristic feature of the Tukan is a downward pointing boom tip which shortens the boom head pulley-to-load distance. This considerably reduces the suspension length of hoisting ropes and minimises pendulum swing when braking and accelerating. In addition, short

hoisting ropes give a reduced spring effect so that loads show better rotational stability when slewing. A horizontal load path with a boom close to the load gives you a major advantage: the crane driver will find it easy to take up and put down loads and at the same time can work with great precision – in all kinds of weather. The Tukan's short suspension lengths also make it ideal for semi-automatic operation.

Short rope lengths cut costs. Optimum rope guides minimise the number of bending cycles so that ropes and pulleys undergo less strain and have a much longer service life. Your advantage in this case: major cost savings for procurement, maintenance and repairs, longer rope replacement intervals and thus greater availability.

The specific double jib feature of the Tukan is a movable counterweight. This ensures dead weight compensation when the outreach changes, keeps the jib system's centre of gravity near the rotational axis in any position and minimises the moments acting on the slewing ring. The movable counterweight supports luffing in such a way as to limit luffing forces, which results in less wear and lower operating costs.

→ **INFO**

**Tukan characteristics:**

- extremely productive: the double jib concept shortens load paths/ropes/suspension lengths, favourable position of centre of gravity position, maximised on positioning accuracy
- completely safe: with four bar linkage
- very flexible: thanks to the slewing bearing
- highly economical: lower procurement/maintenance/repair costs, longer rope replacement intervals, better availability



↑  
Big grabs for maximum performance

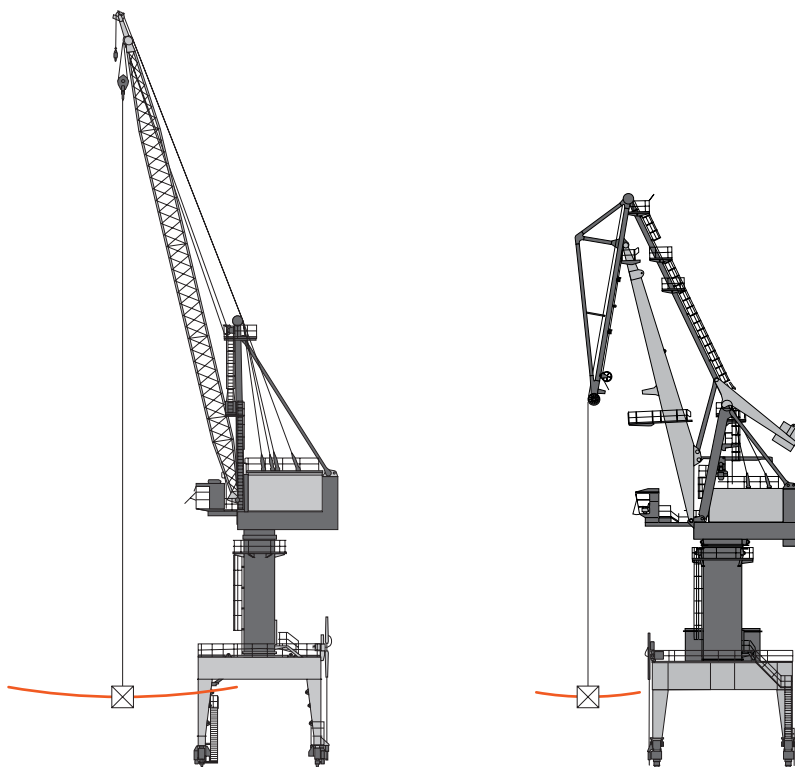

↑  
The double jib concept – short rope lengths, pendulum swing greatly reduced

# MINIMISE PATHS TO SAVE TIME. OPTIMAL AND SAFE QUAYSIDE HANDLING.

Different infrastructures in terminals and shipyards call for different crane designs and features, particularly when it comes to gantries. Their optimal configuration is vital for efficient crane operation. Tukan gantries ideally fit the type of power supply and the gauge and admissible loads of craneways.

The box girder structure with gantry columns in open girder construction makes a Tukan gantry robust, reduces vibration and deformation, and ensures fast and precise handling.

While shipyard cranes depend mainly on craneway features or the layout of assembly areas, the gantries of dock cranes have to suit the arrangement of storage areas and local transport systems. Of great advantage is a Tukan with a high gantry: you can easily travel under it even if the quay is narrow.

The rail-borne travelling mechanisms of Tukan cranes are superior to rubber-tyred versions and much more flexible; a Tukan can travel with the maximum admissible load for a specific outreach and needs no stabilising facility. This saves considerable time and energy as steel wheels are more reliable and their running resistance is three times lower than that of tyres.

Rubber-tyred cranes need expensive stabilisers, have higher safety risks, can not travel under load and act as a barrier to other quay traffic. In addition, their tyres wear out very quickly. The advantages of a Tukan are clear in comparison.

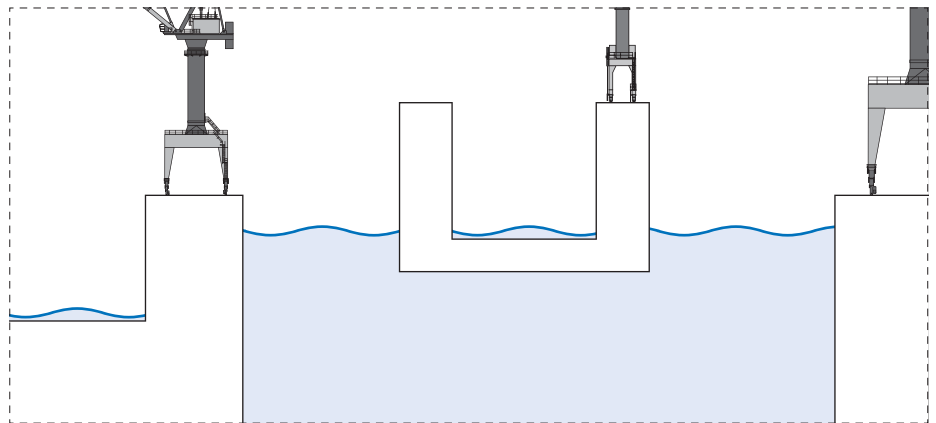

↑  
Gantries to fit dry and floating docks, and quayside cranes

## → INFO

### Tukan characteristics:

- excellent performance: high gantries in modular construction perfectly fit the local infrastructure, plus optimised load paths and working cycles, better reliability give maximum efficiency in operation
- very versatile: enables rapid change of load take-ups
- extremely flexible: can travel under load, no outriggers required, gantries can be under-ridden at any time
- highly economical: ideal for making logistics a success, much lower maintenance/repair costs than for a mobile crane, less power consumption



↑  
Tukan with an asymmetrical gantry





↑  
Gantries present no obstacle to traffic

# WORK WITH ULTIMATE PRECISION, OPTIMUM MAINTENANCE. DRIVERS AND OPERATING COMPANIES WILL LIKE THIS CRANE.

USER-FRIENDLY OPERATION  
AND MAINTENANCE.



The driver's seat is comfortable enough for fatigue-free working. There is air conditioning and heating to ensure the right temperatures for every climate zone. That's why the Tukan is different, and those who have been in the driver's seat appreciate the maximum performance achieved.

Operating companies give priority to best possible maintenance and long-term spare parts supplies. This is why we seek to make all areas maintenance-friendly and accessible, with easy-to-climb stairs and comfortable maintenance platforms. Main access is via stairs on the gantry. The boom itself is built and designed so as to support necessary maintenance work. Inspections, servicing and repairs can be carried out safely and quickly at minimal cost.

Maintenance is assisted by well-designed auxiliary systems in the form of touchscreens in the cab and electro-container. Special features such as slack rope/overtemperature/overload/overspeed and collision protection reduce both wear

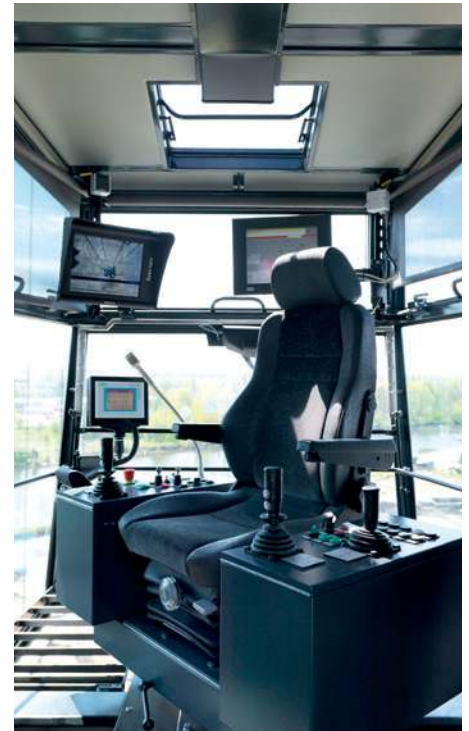

↑ Driver's cab: comfort and functions combined

and the probability of failure. Through a tele-diagnostic service specialist Ardelt personnel can give support readily and at short notice.

↑ The load is easy to see from the cab

You can expect the best handling performance if the human factor and technology interact perfectly. Ardelt cranes give you ease of use and ideal conditions for safe and stress-free working.

The driver's cab is accessible via stairs and provides an excellent view of the ship and quayside at all times. The material being handled is permanently in the driver's field of vision. The Tukan's mechanical functions enable extremely precise working and perfect positioning accuracy. Controls in the cab are ergonomically designed and arranged, and operation is made easier by an innovative interface for the touchscreen.



↑ Maintenance-friendly: even the boom is accessible via stairs



A servicing and diagnostic interface which has been newly developed for the Tukan is another major step toward easy operation, and benefits the driver, operating company and service personnel alike.

The menu mode of the interface is clear, self-explanatory and provides the driver with vital information through a very simple selection procedure on the user friendly touchscreen.

#### Functions are clearly shown

At first glance the driver sees vital data on the screen and can then easily access other information regarding, for example, the hopper or partial automation, by going to the icons on the right-hand side of the screen. These appear permanently so that the driver need not go back to the initial screen or other previous screens, making operation more comfortable and easier to understand.

#### Data acquisition made easy

The status of particular functions is shown by icons and counters and can thus be analysed and assessed quickly and reliably even off-site, if required, by customers. Maintenance and servicing staff can then evaluate all operating and consumption data on site or at any time they choose. A need for maintenance and potential savings can be recognised earlier, making handling operations safe, efficient and less costly.

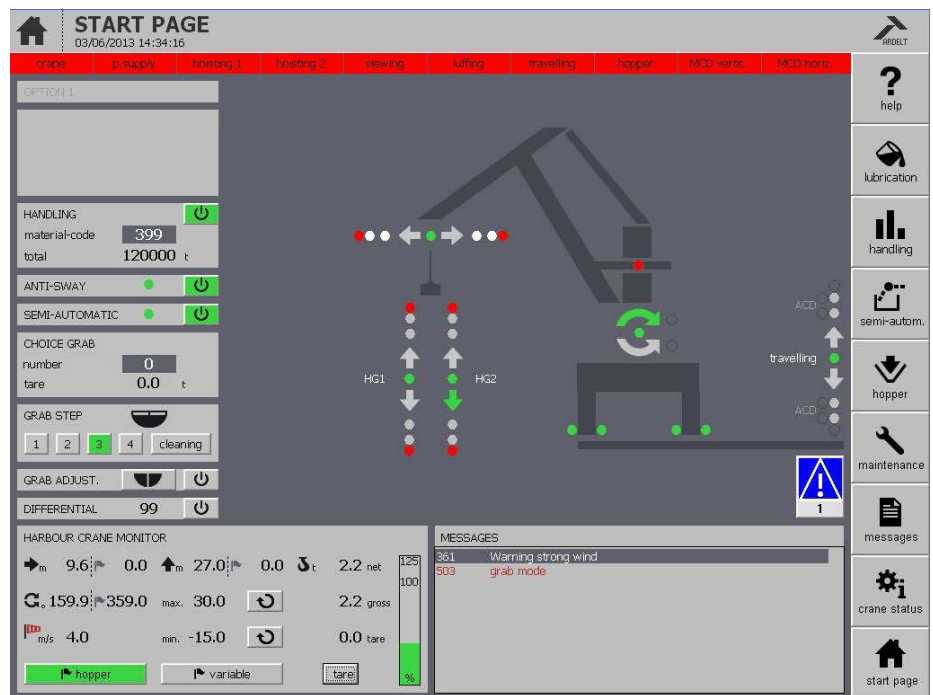

↑  
Tukan screen with initial key information

#### → INFO

##### Tukan characteristics:

- informative easy operation:  
ergonomically designed driver's workplace giving an optimal view, touch-screen with ample information, precise handling, partly automated, optimised grab filling
- easily accessible:  
easy-to-climb stairs and maintenance platforms, spacious machinery room
- very maintenance-friendly:  
low-maintenance fully electric drives, long-lived components, automatic lubrication systems, extensive protection/auxiliary systems, tele-diagnostic service
- very economical:  
minimum wear, low maintenance and repair costs, long service life

# HOW TO BENEFIT FROM EFFICIENCY AND TOP PERFORMANCE. OUR MAIN ASSEMBLIES.

## 01 ELECTRO-CONTAINER

This comes in modular construction with air conditioning and accommodates all switch cabinets clearly arranged in groups and easily accessible. The cabinets incorporate bespoke state of the art components which, after complete installation, are thoroughly tested together with the driver's cab and then supplied as a unit.

### Advantages:

- minimum installation work
- short final assembly periods
- excellent overview of the crane's functions and electrical installation
- access to all components for servicing



↑ High quality components in the electro-container

## 02 MACHINERY ROOM

This is located on a spacious machinery platform together with the electro-container, driver's cab, stationary counterweight, the frame accommodating the movable counterweight, and the derricking gear. From here one can easily reach all sections of the crane. The large and well-ventilated machinery room provides good access to all components for inspection, maintenance and repairs. An integrated auxiliary crane can lift or

lower loads once a number of floor plates have been removed. Optional: an auxiliary winch for replacing hoisting ropes. There is perfect protection against water penetration in the form of floating pulley lead-throughs with proven seals on rope feed-throughs in the roof of the machinery room.



↑ Machinery room: spacious and maintenance-friendly

## 03 HOISTING GEAR

A Tukan crane may have up to three hoisting winches depending on its proposed use. These are driven by powerful asynchronous motors with torsionally flexible couplings and compact gear units in modular construction. Extensive safety devices prevent damage even in the case of power failure.



↑ Rope pressure device for safe winding of hoisting ropes



↑ Proven hoisting gear block

## 04 SLEWING GEAR

In a Tukan crane this consists of compact low-maintenance drive mechanism groups incorporating asynchronous motors with torsionally flexible pin couplings and high-performing planetary gear sets. We use only slewing rings from leading manufacturers. Bolted joints designed for long service life and pre-stressed for high performance guarantee reliable operation even under fluctuating loads. Centralised automatic lubrication greatly adds to the service life of the slewing gear.



↑ Long-lived and requiring little maintenance – Tukan slewing gears



### 05 LUFFING GEAR

Depending on crane size, single or double rack and pinion gears are used. They are extremely reliable and easy to service. The luffing drive is relieved of loads by the movable counterweight. A long service life and operating costs much below those of hydraulic or spindle-type luffing gears are guaranteed.

### 06 TRAVELING GEARS

With modular construction all requirements on travelling gears arising from the infrastructure of a site can be readily met. We use only proven components from leading manufacturers.

Travelling gear sections consist of suspension arms and driven/idling wheels. The system as a whole evenly distributes vertical loads on the craneway. Travelling gears made by Ardelt are particularly robust. Their high operating reliability derives especially from involute toothing between the slip-on gear mechanism and the drive shaft.



↑ Reliable and safe – rack and pinion derricking gears



↑ Fully electric rail-borne travelling gears: safe and effective

# IN THEORY: THE PERFECT CRANE TO MEET ALL REQUIREMENTS. IN PRACTICE: THE TUKAN M.

The multipurpose Tukan is an all-rounder and at home on all quaysides where a variety of loads have to be handled.

It is particularly adaptable on universal terminals where it efficiently handles most goods, quickly changes load take-ups without extra tools and aids, and moves containers or general cargo smoothly, precisely and safely. This highly economical all-rounder is also ideal for handling various types of bulk goods from ships of different sizes and loading them into hoppers, rail wagons or trucks.

Even companies specialising in bulk goods loading and unloading can use the Tukan M to add project cargo handling to their portfolio and thus make better use of crane capacity. This gives port operators a clear logistical advantage.

## → INFO

**The Tukan M – a versatile all-rounder, ever-ready for work:**

- unmatched efficiency with a grab for bulk goods
- excellent positioning accuracy with a hook for general cargo
- minimum cycle times with a spreader for container handling
- loading sheet metal plates and scrap with a magnet
- carrying very heavy loads with care in tandem operation

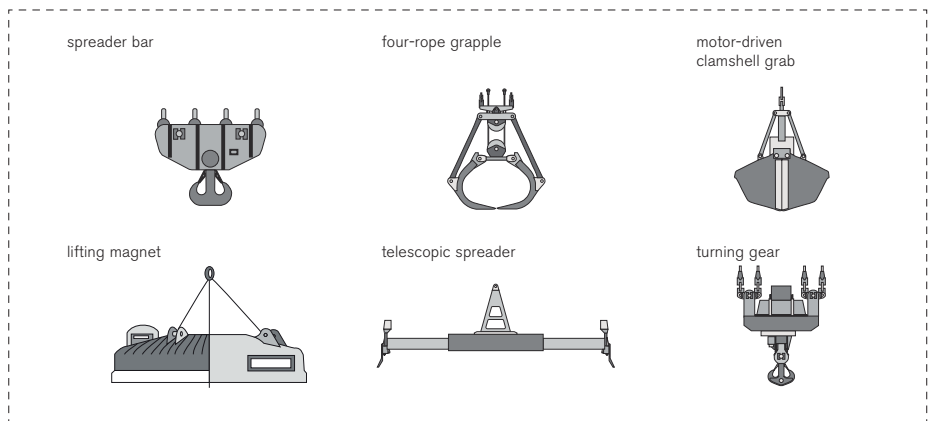

↑  
Tukan load take-ups

For example: success in Vietnam. Over 30 Tukan cranes are giving reliable service there in all kinds of weather round the clock, and more are being commissioned every year. From newcomer to the market leader for double jib slewing cranes – that's Ardelt's success story over a period of only 15 years. For example, ports at Haiphong and elsewhere in North Vietnam use the Tukan as a multipurpose crane day in and day out for trans-shiping raw and building materials and containers, and in project cargo handling. The simple reason is that port companies there have full confidence in the design,

construction and quality of these cranes and therefore keep adding new ones. A particular advantage is the high gantry of the Tukan as under-riding is a must on the quayside. In the country's rough climatic conditions these fully electric cranes have performed for many hours and, thanks to their excellent quality, have lost none of their reliability. In addition, secondary power supply helps to deal with difficult mains conditions such as power failures.

Port companies in Haiphong are absolutely sure that the Tukan M is a worthwhile investment.



↑  
Port companies in Haiphong/Vietnam rely on Tukan cranes



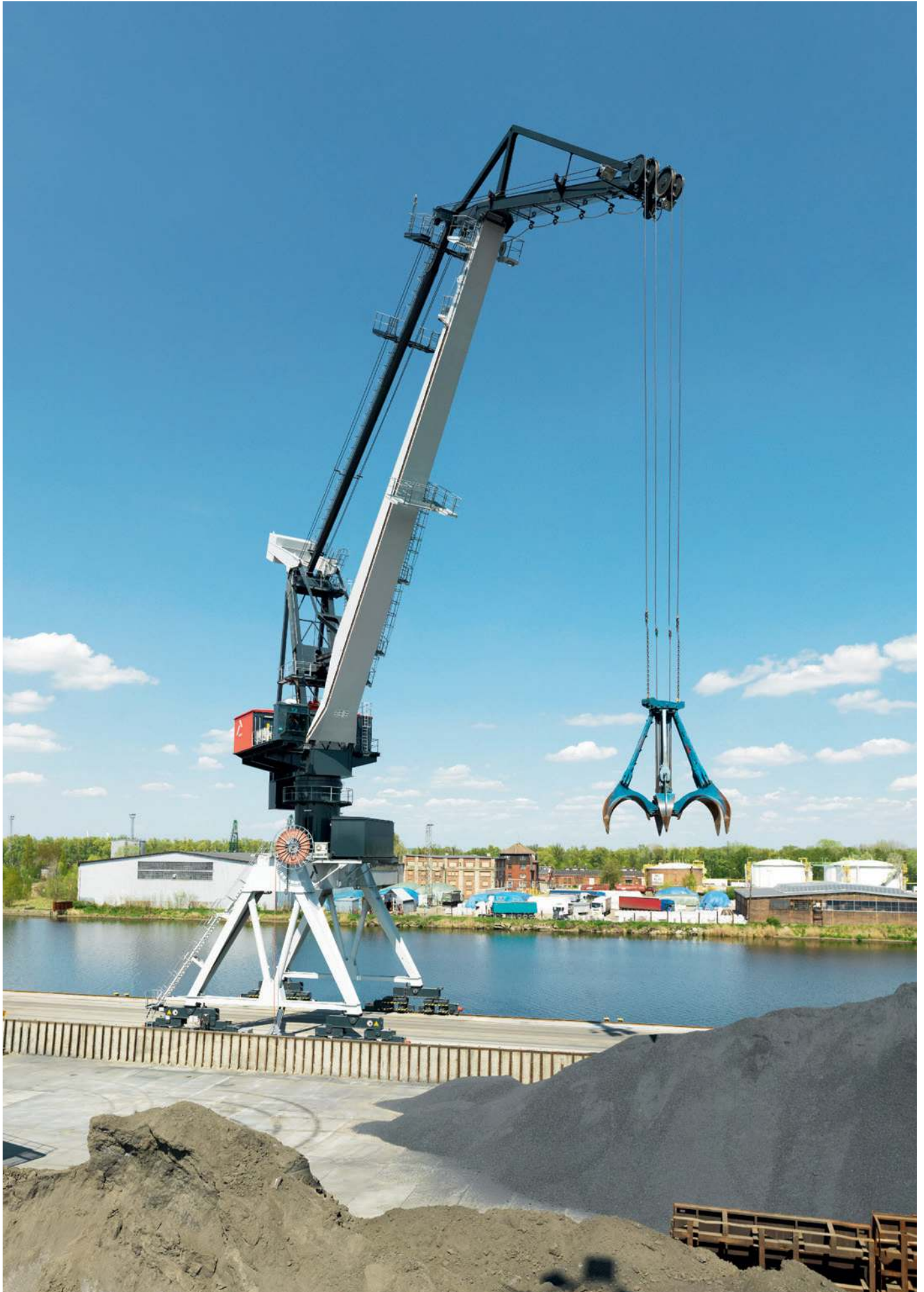

↑ From bulk goods to scrap – the Tukan M load take-up can be changed in a matter of seconds





Tukan M supplied with hopper

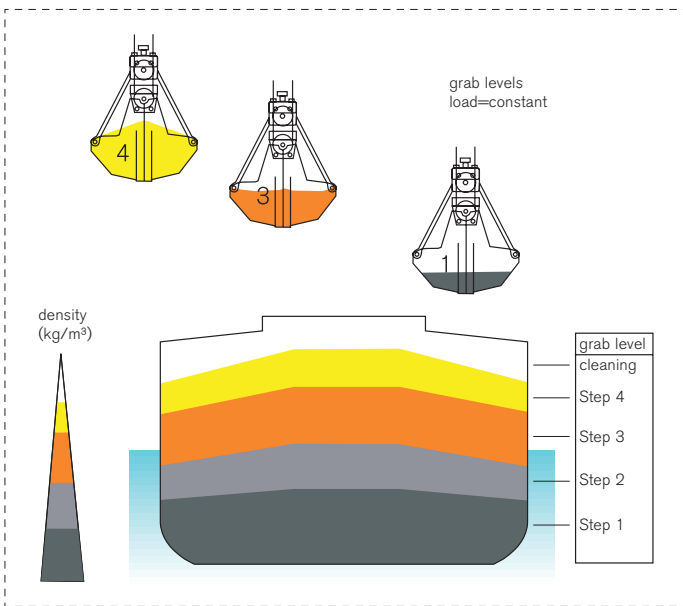

Grab filling optimisation for better efficiency

Example - bulk handling:

For this the Tukan M is ideal because its robust double jib construction minimises wear under rugged quayside conditions. Equipped with a two-drum grab hoisting gear as standard it can be used in four-rope grab operation. Major advantages

compared with a motor-driven grab include much shorter opening and closing times and a lower dead weight of the grab. There is no need for a separate power supply as required for a motor driven grab. Another advantage developed in-house is patented grab filling optimisation for better efficiency.

This intelligent system adapts the grab's filling volume to the density of bulk goods so that fewer grab changes are needed. At the same time, efficiency is improved because handling capacity can reach a maximum and grab capacity may be utilised to the full, making overload cutouts a thing of the past.

Since the role of environmental protection particularly in bulk handling has grown over the years, Ardel has come up with a number of solutions to ensure cleaner handling such as semi-automatic operation. This procedure defines the target point for an automatic approach and optimizes the drop height so that undesirable dust and noise emission are avoided. Simple mechanical systems such as Flex-Flap or high dust protection walls are integrated into supplied hoppers. Alternatively, goods giving off medium and high dust levels can be treated with active systems which use sprinklers or sprayers to moisten the material. Dust may also be extracted via a filter system.

The Tukan M – a professional bulk handler.





Tukan M for container trans-shipment

#### Example container handling:

Here again the Tukan M is the world's most efficient crane, which is inherent in a system where double jib cranes have hoisting ropes with short pendulum swing. As a result, the spreader can be very accurately positioned and the load precisely set down. In addition, the direct electric drives allow the crane driver to feel crane movements so that he can expect best possible acceleration, control and braking of loads. From the cab the driver has a perfect view of the quayside and the ship.

During container handling the Tukan M shortens the loading cycle, performs more cycles and thus improves loading capacity while reducing operating costs.

#### Example general cargo handling:

Here, too, a Tukan M with crane hooks is ideal for the job as the advantages of ropes with low pendulum swing can be used to the full. Precise working greatly reduces the risk of causing damage in transit, even when operating in tandem with a neighbouring crane. Trans-shipment of heavy parts is possible with a heavy lift facility.

The Tukan M for general cargo handling: accurate positioning also in tandem operation.

A summary: If an all-round universal crane is required the Tukan M is the right choice. This double jib level luffing crane is a pacemaker when it comes to versatility, operating costs and operating life. Lifetimes of over 25 years even with more than 3,000 operating hours per year, and uniquely low maintenance costs throughout a life cycle have been reported.

The Tukan M – always a worthwhile investment for universal terminals.



Heavy load handling of parts for wind turbines in tandem operation

# ACCURATE AND SAFE IN SHIPYARDS.

## THE TUKAN S.

THE TUKAN S  
AT WORK.

This specialist shipbuilding crane made by Ardelt differs from the Tukan M in that its construction is lighter. It has a rating for operating at shipyards and working speeds suited for assembly operations. Strict allowance is made for specific requirements regarding outreach and lifting height. Gantries are suitable for under-riding, a logistical advantage in shipyards with confined conditions.

Shipbuilding in particular is an operation where heavy parts need to be kept accurately in position under completely safe conditions, sometimes for longer periods. This is vital for welding and assembly work. This fully electric double jib level luffing crane is sufficiently reliable and has the positioning accuracy for handling sensitive and high-value parts for ship-fitting. Here the advantages of double jib construction pay off in that optimised direct rope guidance and short ropes prevent undesirable pendulum swing.

If necessary the Tukan S may be equipped with an auxiliary hoist. This can work at a much higher speed than the main hoist if only small parts are handled. Smaller parts may be rotated or turned over with the main and auxiliary hoist, and the latter can help stabilise bulky loads suspended on the main hoist.



↑  
The Tukan at Admirals Shipyards in St. Petersburg/Russia

A summary: The Tukan S is the ideal, reliable, low-maintenance shipyard crane with a long service life and low operating costs. Its versatility makes it perfectly suitable for nearly all shipbuilding lifting and positions tasks.

The Tukan S is a worthwhile investment for shipyards particularly over a long duration.

### → INFO

#### The Tukan S – a reliable shipyard crane:

- maximum positioning accuracy
- extreme reliability
- low operating costs
- long service life





↑ Double jib level luffing cranes at Blohm + Voss shipyard in Hamburg/Germany

# DESIGNED FOR A LONG HIGH-PERFORMANCE SERVICE LIFE. ROBUST CONSTRUCTION, FIRST-RATE COMPONENTS.

LONG LIFE,  
RELIABILITY  
AND SAFETY.

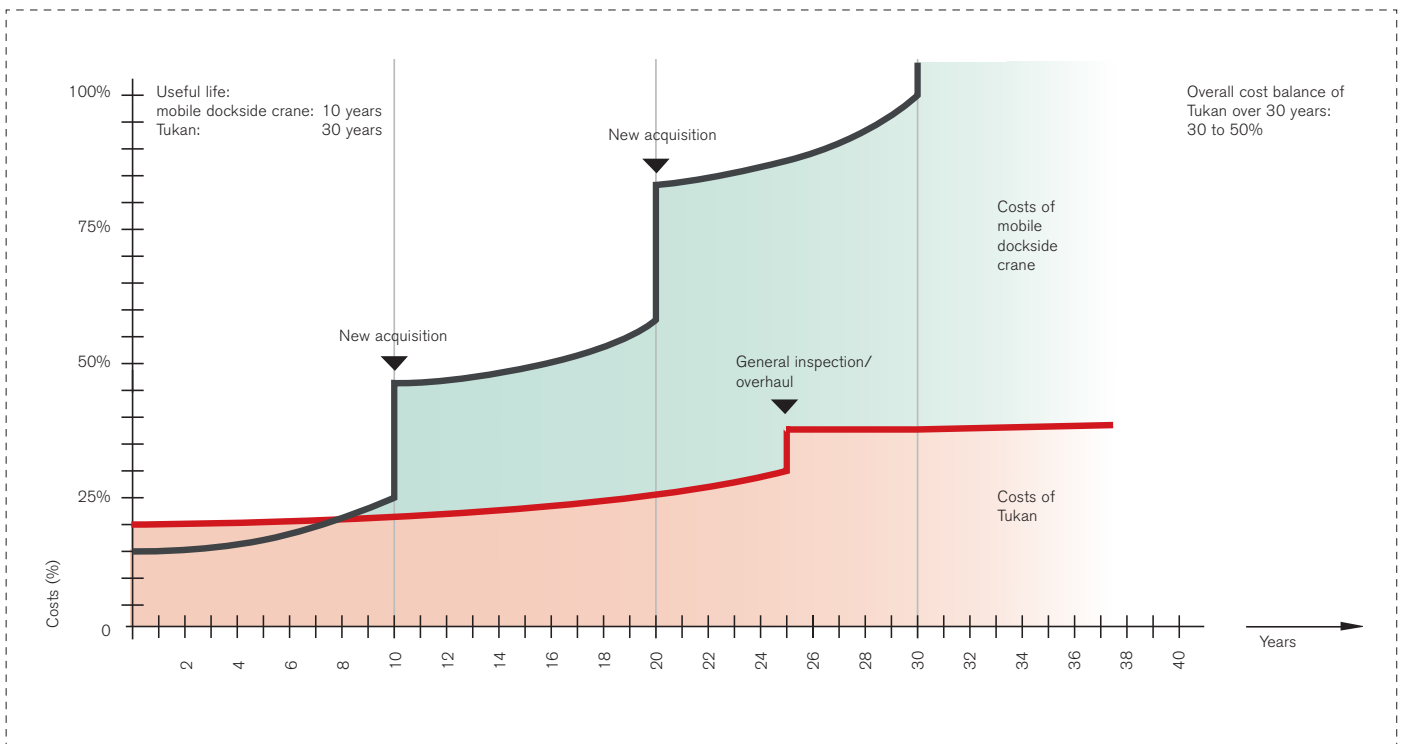

↑  
Life cycle costs compared

Quayside and shipyard cranes are at work all the time and therefore need high performance, reliability and availability as reflected in perfect functions, a long useful life and low maintenance and repair costs. Ardel cranes live longer and can easily give you more than 25 years of service. Their steelwork has been strictly designed for longevity and the best possible workmanship has been used.

Specific designs optimally adapt the cranes to customer requirements. All Tukan cranes have fully electric drives and thus emphasise environment-friendly, energy-saving and economical performance.

The consistent use of proven high-quality components makes for longer maintenance intervals and a longer service life.

A case in point is the rack and pinion derriking gear which is far more robust than hydraulic drives due to its balanced system and first-rate components. We have made it our business to use only components from leading manufacturers with long-term availability; just one way of achieving return-on-investment quickly.

One example: should a rope on the Tukan become due up for replacement, the operation should take just a few hours – without having to use an expensive extra mobile crane.

These short ropes can be easily replaced by tying on a new rope with the hoisting gear.

Another advantage of the double jib system is that there is very little stress on

the boom sheaves because the boom tip always points downward giving little room left for pendulum swing. Sheaves hardly ever need replacement throughout the lifetime of the crane.

In view of the long service life of a Tukan crane, intelligent reactivation may be more economical than buying a new crane. Ardel has customised solutions for the latest drives and control systems, and for upgrading hoisting, slewing and derriking gears. For example, two Tukan cranes were rehabilitated at a coal-fired power station in Berlin after 28 years of uninterrupted bulk handling. They can now continue over a long period and handle more than a million tonnes of coal per year.



# WHY ARDELT?

## MANUFACTURERS OF CRANES SINCE 1902.

### → KNOW-HOW

Ardelt is a world market leader and has sold more than 2,700 double jib cranes. We continue to work on the basic engineering document, the double jib patent granted in 1932, in the search for maximum performance.

In this effort at improvement, our experts strictly apply the proven German engineering standards and give particular attention to the design and classification of cranes for continuous duty. The aim is always to improve the efficiency, safety and environmental acceptability of cranes.

### → QUALITY

For us this involves a well-thought-out product concept, solid know-how in such

fields as design and control, maximum precision in manufacture and best workmanship. As a matter of course, our engineers test every detail of a mechanical or electrical sub-assembly.

### This gives you major advantages:

- maximum performance and reliability of cranes
- low operating costs
- a long service life (even under the most rugged conditions)

### → SERVICE

A good product deserves perfect maintenance and repairs. This is why we thoroughly brief customer staff on the theory and practice of cranes. The aim is to guarantee constant availability. Should a breakdown occur despite these

precautions, we will help at once – day or night.

Rely on our excellent service and the intelligent reactivation techniques we have developed to give your used crane, whatever the make, a second life.

### → PARTNER APPROACH

A Tukan has an extremely long useful life, and buying one is normally the beginning of a many-sided customer/supplier relationship which often leads to repeat or follow-up orders.

We therefore attach great importance to making this relationship a fair one which benefits both parties. For us this philosophy applies long before a contract is signed. We would be glad to tell you more, please give us a call.



↑  
Ardelt company building in Eberswalde/Germany

# TUKAN MULTIPURPOSE – A SERIES AND ITS ESSENTIAL TECHNICAL DATA.

THE TUKAN  
MULTIPURPOSE  
AT A GLANCE.

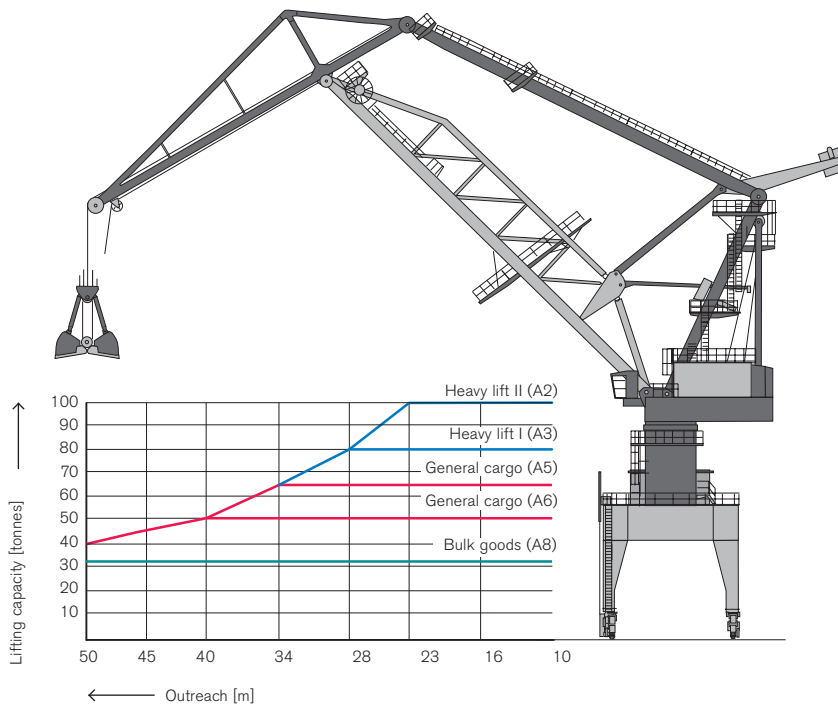

Example: The Tukan Multipurpose 2000 with lifting capacity diagram (highlighted in grey in the table below)

The Tukan Multipurpose series listed in the lower table gives a first survey of essential data. For example, the highlighted grey column shows key data for the Tukan Multipurpose 2000. Look

above for the related lifting capacity diagram and chart. Similar data for other cranes in the Tukan Multipurpose series is available upon request.

	→ CRANE TYPE TUKAN MULTIPURPOSE				
	M 750	M 1000	M 1500	M 2000	M 3000
→ LIFTING CAPACITY [TONNES] AND (CLASSIFICATION)					
Grab operation	16-20 (A8)	20-25 (A8)	25-32 (A8)	32-50 (A8)	32-50 (A8)
Hook operation	25 (A6)	50 (A5)	50 (A5)	63 (A5)	63 (A5)
Heavy lift operation	up to 45 (A3)	up to 63 (A3)	up to 80 (A3)	up to 100 (A2)	up to 120 (A2)
→ MAX. OUTREACH [M]	up to 32	up to 40	up to 45	up to 50	up to 63
→ BASIC GAUGE [M]	10	10	12	12	12
→ MAX. SHIP SIZE BULK CARRIER [DWT]	Handysize up to 40,000	Panamax up to 75,000	Post-Panamax up to 85,000	VLBC up to 220,000	Direct unloading from Post-Panamax to barge

Key data for Tukan Multipurpose series



# THE TUKAN SHIPYARD – KEY TECHNICAL DATA OF THE SERIES.

THE TUKAN SHIPYARD  
AT A GLANCE.

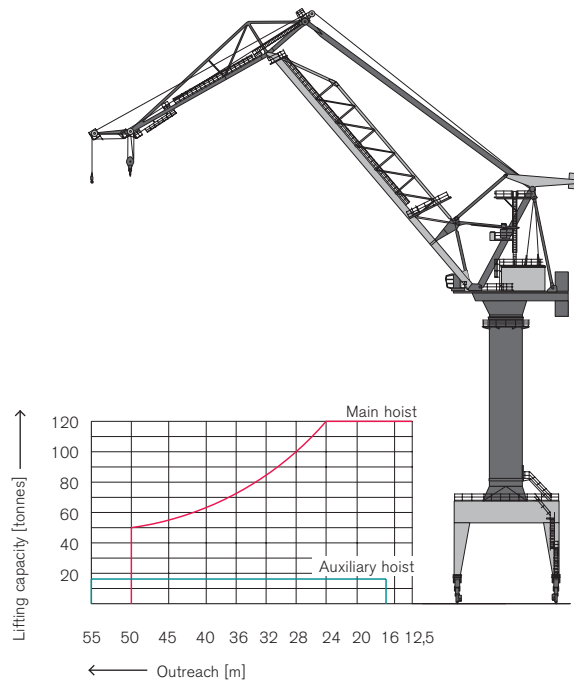

↑ Example: Tukan Shipyard 3000 with lifting capacity diagram (highlighted in grey in the table below)

	→ CRANE TYPE: TUKAN SHIPYARD			
	S 1000	S 2000	S 3000	S 5000
→ MAX. OUTREACH [M] FOR MAIN HOIST	up to 32	up to 45	up to 50	up to 80
→ LIFTING CAPACITY [TONNES] FOR MAIN HOIST AND (CLASSIFICATION)				
Step 1	50 (A5)	63 (A5)	100 (A5)	100 (A5)
Step 2		50-80 (A4)	100-120 (A4)	100-160 (A3)
Step 3				160-250 (A1)
→ MAX. OUTREACH [M] AUXILIARY HOIST	up to 35	up to 50	up to 55	up to 85
→ LIFTING CAPACITY [TONNES] OF AUXILIARY HOIST AND (CLASSIFICATION)	10 (A6)	16 (A6)	16 (A6)	20 (A6)
→ MAX. LIFTING HEIGHT [M]	36	50	60	60
→ MAX. LOWERING DEPTH [M]	10	10	15	15
→ MAX. BACKWARD OUTREACH	7.5	7.6	10	12.5
→ BASIC GAUGE [M]	10	10	12	16

↑ Key data for Tukan Shipyard series

## **KRANUNION.** WORLD MARKET LEADERS UNITED.

Kranunion is an association of three crane manufacturers who specialise in lifting and transporting heavy loads:

- KIROW is the world market leader for railway cranes and slag pot carriers
- ARDELT is the world market leader for double jib level luffing cranes
- KOCKS is the world market leader for Goliath cranes and a pioneer in the development of container cranes

Central to all Kranunion products are the technical design concepts created by our experts. Of course, we continue to optimise those fundamental concepts even further in the interests of our customers. Kranunion products are therefore based on practical requirements and are a symbiosis of tradition and innovation combining the tried and tested with the new.

Customers who choose Kranunion choose great German engineering skill: for environmentally-friendly and safe, modern technology, for low operating costs, for high performance and reliability.