

TUKAN KANGAROO 750 / 1500 / 3000

DOUBLE JIB LEVEL LUFFING CRANE
WITH INTEGRATED HOPPER



ARDELT



↑ Handling of bulk material in Chile

THE TUKAN KANGAROO: THE SPECIALIST FOR HANDLING BULK MATERIAL.

THE PERFECT CRANE-SYSTEM
FOR HANDLING BULK MATERIAL.

Bulk material corresponds to a large percentage of the global movement of goods. Ores, coal, raw sugar, sand, stones and more recently also wood chips for special power stations have to be transported from the places of their extraction to the places of their further utilization.

This mostly takes place on waterways – therefore, the corresponding specialised devices for the handling of goods in the harbours are required. Here, the loading is a relatively simple process as these bulk goods can be dumped. The unloading and ensuring the smoothest possible further transport of the goods is, however, a highly demanding process. Here, cranes play an important role as high performance devices.

→ INFO

What are the features of the best machines for the unloading of vessels?
What is important?

→ Essentially, the most important features are:

- low operating costs (smooth interfaces)
- high level of labour productivity (fast and secure handling)

→ And in detail:

- a sophisticated technical crane concept
- lossless working
- reliability and a high level of availability
- long service life
- low maintenance costs

→ And, naturally:

- environmental friendliness (low energy consumption, low levels of dust and pollutant emission, low noise level)

The Tukan Kangaroo meets all these criteria.

It is the bulk material efficiency machine that provides the highest levels of environmental friendliness.



From the ship into the hopper

THE CRANE WHICH ALWAYS TAKES THE SHORTEST ROUTE: THE TUKAN KANGAROO WITH INTEGRATED HOPPER.

THE TECHNICAL CONCEPT.

The Tukan Kangaroo is a special Tukan model – equipped with a hopper integrated on the seaside (like a kangaroo pouch). The corresponding outlet devices are installed on the underside of this hopper. This enables the loading of lorries, trains, conveyor belts and other means of transport and/or the dumping of bulk material at storage sites and stock piles.

The Tukan Kangaroo works highly efficiently, always taking the shortest route:

1. The grab dips into the bulk material (in the vessel);
2. it is lifted until it is just above the height of the hopper
3. The jib is luffed and
4. the grab is emptied over the hopper.

Besides, this is a completely relaxing working method for man and material: There is practically no rotation which could be arduous for the crane operator and put strain on the crane itself. And thanks to the intermediate storage function of the hopper there are no waiting times for subsequent means of transport.

Depending on the individual case, the following applies for the optimal layout of the hopper: Here, our long years of experience with all kinds of bulk materials proved to be of great help. When deter-

→ INFO

Typical for the Tukan Kangaroo:

- **highly efficient and user-friendly:** it always takes the shortest route, no rotation, semi-automatic operation possible
- **extremely flexible:** The hopper is optimally laid out for every application
- **Tukan-like in every aspect:** short load paths, short rope and pendulum lengths, beneficial position of the centre of gravity: the double jib principle
- **extremely environmentally friendly:** low energy consumption, low dust emissions, low noise level

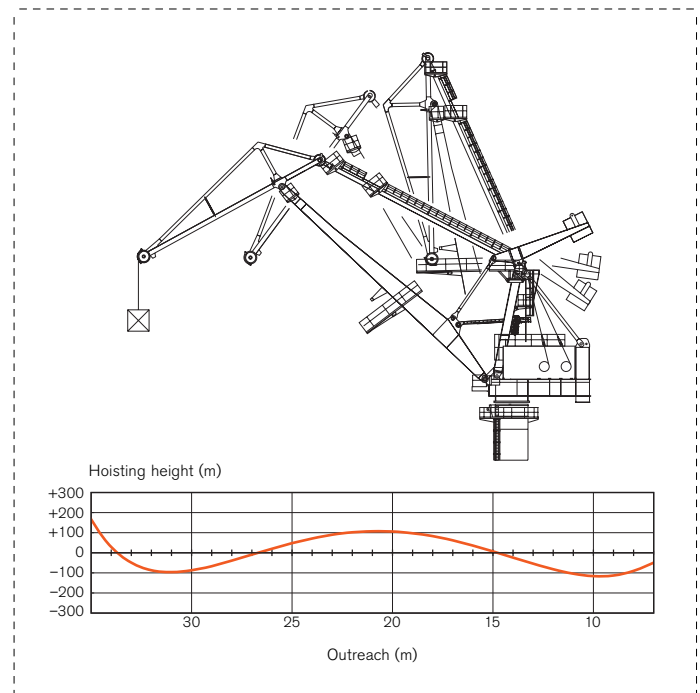

↑
Jib system – horizontal load path

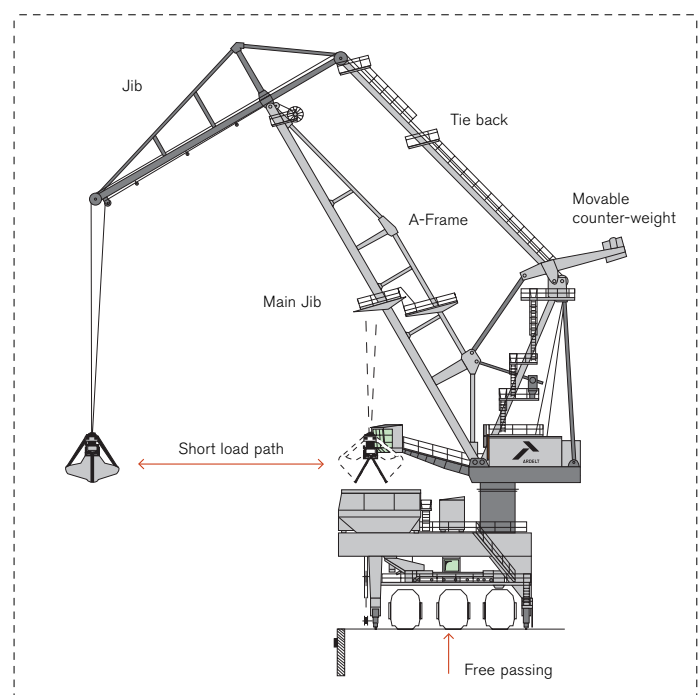

↑
Kangaroo-operation



↑
Close to the action

mining the geometry of the hopper, criteria such as density, free flow property and abrasiveness of the bulk material are taken into consideration when it comes to its interior lining and outlet devices.

The following features are also typical for the Kangaroo crane: Despite the hopper, the gantry can still be passed. The loading of the means of transport can thus take place both inside and outside of the crane profile. Apart from that, there are special grabs for all kinds of bulk material, which guarantee an unloading without any losses; there is furthermore the possibility of semi-automatic operation. Here, the crane operator only needs to be active when picking up the load. Moreover: The loss of goods when opening the grab can be prevented by a spill plate. Apart from the benefits of the integrated hopper, the Tukan Kangaroo is and remains a Tukan. Including all the basic advantages these legendary double jib level luffing cranes provide. Featuring a mechanically

realised horizontal load path, minimised lifting movements and a reduced dynamic load. Its jib system balanced with a counter-weight lever ensures low luffing forces. The forward positioned cabin allows for perfect visibility. This means: When the Tukan Kangaroo has to rotate, it is able to rotate. And if general cargo and containers are to be unloaded, this does not pose a problem, either. The closeness of the top of the jib to the goods to be unloaded enables precise positioning – while the short rope lengths prevent a pendular movement of the load suspension device.

If nothing else, the Tukan Kangaroo has been developed and designed as an extremely environmentally friendly and sustainable crane. Its already low primary energy consumption is further reduced by its state-of-the-art converter technology. Through a recovery of the (not used) braking energy into the supplying grid, the Tukan Kangaroo has a significantly better energy balance than comparable,

mobile harbour cranes. Regarding the subject of efficiency as an active form of environmental protection: Most bulk materials naturally raise dust when being moved. We make every effort in order to prevent as much raising and blowing away of dust as possible: For means of preventing dust and for dedusting, the Tukan Kangaroo can therefore, among others, be equipped with special dust protection walls and dedusting filters.



↑
The interior of a hopper

THERE ARE MANY REASONS TO DECIDE FOR **THE TUKAN KANGAROO**. HERE THE MOST IMPRESSIVE ONES:

THE TECHNICAL HIGHLIGHTS.

01 THE PORTALS

Tukan Kangaroo portals are always tailor-made. We manufacture them to meet on-site requirements; this means: In the areas of "Hopper outlet possibilities" and "Travelling gear configurations", we can fulfil almost any request.



↑ Ardelt portals are customized to the individual requirements

02 THE DUST PROTECTION TECHNIQUE

One of the key aspects for ensuring the environmental friendliness of our cranes is it to take suitable dedusting and dust-prevention measures. For example: Dust-protection walls with semi-tube sections as closing-off are attached to the edges of the hopper. Apart from that, the hopper grate of the Tukan Kangaroo can be equipped with Flex-Flap-Systems. Dust suppression systems based on water atomisation and dedusting filters with air extraction devices can also be integrated.

APART FROM THAT THE TECHNICAL HIGHLIGHTS OF THE TUKAN ALSO APPLY FOR THE TUKAN KANGAROO, AS FOLLOWS:

03 THE HOISTING GEAR

We have optimised our hoisting gear through decades of development, so we are able to guarantee highest performance and best availability. They are equipped as standard with compact, high-performance planetary gears of modular construction. In this way we achieve weight and cost savings.

04 THE DOUBLE JIB LEVEL LUFFING SYSTEM

Decades of experience pay off. Ardelt builds what is not only the most robust, but also the lightest double jib level luffing system in the world. The Tukan Kangaroo is manufactured in three size classes, each with specific characteristics related to the size: Tukan K 750, Tukan K 1500, Grande Tukan K 3000.



↑ Dust-free movement of goods

05 THE ELECTROCONTAINER

We only install first-class components in the modular-designed Tukan Kangaroo electrocontainer. We manufacture the control cabinets, for example, in Eberswalde, install them completely, test them meti-culously and then deliver them as a compact unit together with the operator cabin.



↑ Open electrical racks increasingly popular

The benefits:

- well-arranged structure thanks to the modular design
- high-quality components and functional testing
- low freight costs thanks to reduced dimensions
- less installation work during assembly.



↑ Well-tested hoisting gear block



↑ Travelling gears from the construction kit

06 THE TRAVELLING GEARS

For the Tukan Kangaroo we only use tried and tested components from well-known suppliers because we believe that reliability is a cardinal virtue. Travelling gear systems from Ardelt characteristically have an extremely robust design with one very special feature: the driving dogs between drive and drive shaft have involute toothing. This makes it possible to easily replace the drive units. Ardelt travelling gear units are modular in design and – as modules – can be combined on travelling gear balancers. In this way they can easily meet all the requirements that the infra-structure of the respective installation site demands. Moreover: in comparison to a rubber-tyred travelling gear, a rail mounted travelling gear is less expensive to purchase and maintain because the high cost of tyres is eliminated.

07 THE MACHINERY HOUSE LAYOUT

Typical for the extremely easy-maintenance machinery house layout is the excellent accessibility of all components. The rope entry funnel into the machinery house roof is provided with excellent protection against rain or spray water by means of floating guide rollers (with reliable sealing).



↑ The spacious machinery house allows for good reachability and easy maintenance



↑ Visualization of crane data via the crane-management system

08 THE OPERATOR CABIN

Ardelt operator cabins are customised units developed from standardised construction forms. We design and develop them in accordance with our customer's wishes and the operating conditions on site. Furthermore, the view from the cabin of a Tukan Kangaroo is significantly better than the view from a fixed cabin of a ship unloader. Here, the already existing benefits are highlighted in particular: The top of the jib and the cabin are close to the loading cargo; the ship's hatch and the hopper are excellently visible. This eases the optimum positioning of the grabs.



↑ Good view from the operator's cabin

09 THE SLEWING GEAR

The Tukan Kangaroo slewing gear systems are compact, low-maintenance drive units with planetary gears. The slewing bearing is secured with Superbolt connections which prevent any uncontrolled loading of the bolts. No special tools are required for checking the pre-tension settings. Furthermore, the central lubrication system contributes to the ease of maintenance. Which means simply: Tukan Kangaroo slewing gear lasts longer.

10 THE CONTROL SYSTEM

Ardelt is the only manufacturer of double jib level luffing cranes able to refer to an established and integrated knowledge chain: right from the electrical design stage through to programming and as far as manufacture and testing. Something which – apart from agreeable operation of the crane – also gives the customer the satisfaction of always having state-of-the-art equipment. Whether this concerns the components or forward-looking functions such as remote maintenance.



↑ Rope pressing device for safe winding of hoisting ropes

11 THE LUFFING GEAR

The Tukan Kangaroo luffing gear is extremely safe, simple to maintain and unaffected by climatic conditions. Depending on size class, we install either single toothed rack luffing gear or double toothed rack luffing gear. This provides a significant reduction in operating costs in comparison to hydraulic or spindle drive luffing gear.



↑ Reliable and safe – rack and pinion luffing gears

THE THEORY: THE HIGHEST HANDLING PERFORMANCE AT THE LOWEST ENGERGY CONSUMPTION. THE PRACTISE: THE TUKAN KANGAROO.



↑
The Giant of Brunsbüttel

The Tukan Kangaroo is used on quays in inland ports and seaports.

With its high working speeds, its short load paths, its universal usability and its low-weight, it is perfectly suitable for handling bulk material. Here, it reaches peak handling capacities of 2000t/h with an unrivalled low energy consumption of 0,2 kwh/t. Thanks to the Tukan Kangaroo working method, centrifugal

forces, which automatically occur with mobile harbour cranes, can be avoided.

The Tukan Kangaroo with its integrated hopper is the most modern and cost-efficient alternative to conventional ship unloaders. No alternative system works nearly as efficiently as the Tukan Kangaroo.

→ INFO

Additionally, even when handling general cargo and containers, the Tukan Kangaroo can fully make use of the systematic benefits of a double jib level luffing crane:

- high positioning accuracy
- horizontal load path (mechanically secured)
- high speed of work

WHY ARDELT?

CRANE CONSTRUCTION SINCE 1902.

→ KNOW-HOW

With more than 2,300 double jib level luffing cranes delivered, Ardel is the world market leader. The technical basis on which our success is built derives from the "Double jib level luffing patent" of 1932, which we constantly develop further.

During the constant further development and design work, our engineers consistently apply the proven methods and rules of the German engineering industry. With this, the classification and categorisation of the cranes for continuous operation is carried out in an especially rigorous manner. The aim always remains the same: to increase the efficiency, safety and environmental aspects of the cranes.

→ QUALITY

For us, quality means: a sophisticated product concept, in-depth knowledge in the fields of design and control, as well as high precision in manufacture and production. It goes without saying that our engineers meticulously inspect and test all mechanical and electrical subassemblies.

All that brings decisive benefits:

- high performance and reliability of the cranes
- low operating costs
- long working life (even under the severest operating conditions).

→ SERVICE

For us, excellent service means, among others: to be present and available. After all, it's always possible for something unpredictable to happen. For this reason, our customers can contact us around the clock via a Hotline. In order to ensure your safety and satisfaction we employ only highly qualified engineers

and technicians in Customer Service. And not least, we place great value on comprehensive and technically sound training and support for your employees.

→ PARTNER APPROACH

The Tukan is a product with an extremely long working life. A decision to choose the Tukan Kangaroo is synonymous with the start of an extensive customer/supplier relationship – which is evident from the many repeat and follow-up orders.

We therefore place great value on developing this relationship to provide fair and long-term benefits to both parties. (For us, this starts long before the signing of a contract. We will be pleased to advise you, simply give us a call.)



↑
Home of Ardel in Eberswalde



↑
The Offices

THE TUKAN KANGAROO – BASIC TECHNICAL DATA.

TUKAN K 750



Average performance with 16 t grab hoist: 600 t/h coal with a density of 1,0 t/m³

Working speed (± 5%):

- Hoisting/lowering from 0 m/min up to 120 m/min*
- Slewing from 1,0 U/min up to 1,6 U/min*
- Luffing from 0 m/min up to 90 m/min*
- Travelling 20.0 m/min*

*DEPENDING ON LOAD

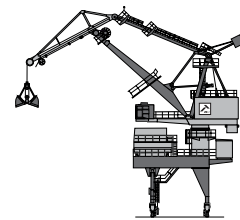
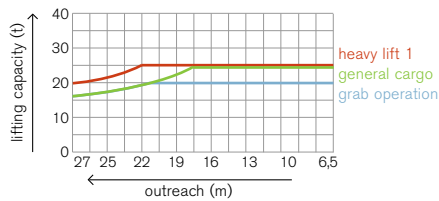

TUKAN K 1500



Medium performance with 40 t grab hoist: 1250 t/h coal with a density of 1,0 t/m³

Working speed (± 5%):

- Hoisting/lowering from 0 m/min up to 120 m/min*
- Slewing from 1,0 U/min up to 1,6 U/min*
- Luffing from 0 m/min up to 90 m/min*
- Travelling 20.0 m/min*

*DEPENDING ON LOAD

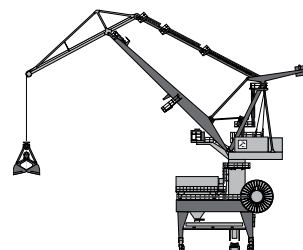
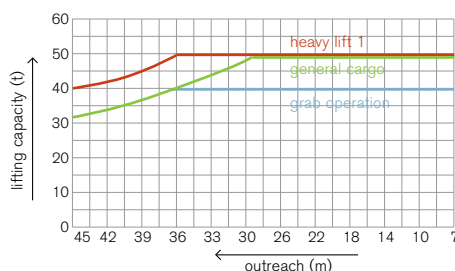

GRANDE TUKAN K 3000



Medium performance with 63 t grab hoist: 1750 t/h coal with a density of 1,0 t/m³

Working speed (± 5%):

- Hoisting/lowering from 0 m/min up to 120 m/min*
- Slewing from 1,0 U/min up to 1,6 U/min*
- Luffing from 0 m/min up to 90 m/min*
- Travelling 20.0 m/min*

*DEPENDENT ON LOAD

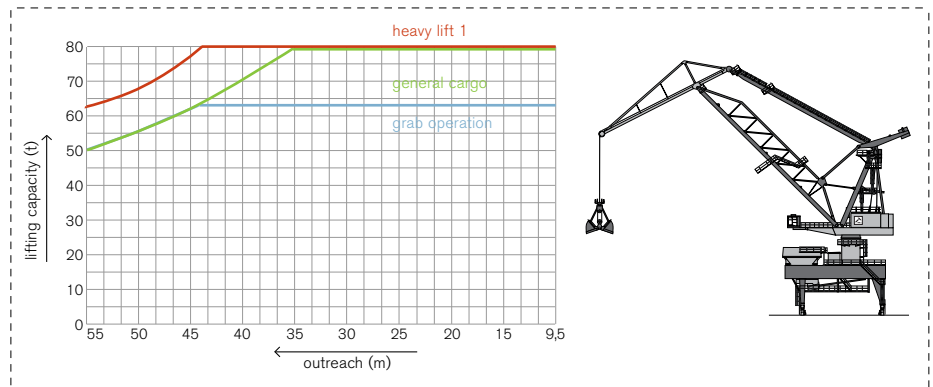

OVERVIEW

	→ INLAND PORTS	→ LARGE INLAND AND SEA PORTS	→ SEA PORTS
<u>Size classes</u>	Tukan K 750	Tukan K 1500	Grande Tukan K 3000
<u>Outreach</u>	27m For ships up to size Saimax	35 m – 45 m For ships up to size Post-Panamax	50m – 55m For ships up to size Capeside and Japanmax
<u>Capacities Bulk goods handling</u>	20t x 27m	30t x 45m 40t x 40m	50t x 55m 63t x 44m
<u>Capacities Heavy Duty operations</u>	25t x 22m	50t x 36m	80t x 44m

KRANUNION. WORLD MARKET LEADERS UNITED.

Kranunion is an association of three world market leaders who have specialised in lifting and transporting heavy loads:

KIROW is the world market leader for railway cranes and slag pot carriers

ARDELT is the world market leader for double jib level luffing cranes

KOCKS is the world market leader for Goliath cranes

Central to all Kranunion products are the technical design concepts created by our experts. Of course, we continue to optimise those fundamental concepts even further in the interests of our customers. Kranunion products are therefore based on practical requirements and are a symbiosis of tradition and innovation combining the tried and tested with the new.

Customers who choose Kranunion choose great German engineering skill: for environmentally-friendly and safe, modern technology, for low operating costs, for high performance and reliability.

