

FEEDER SERVER / POST-PANAMAX SERVER

EFFICIENT
CONTAINER TRANSFER



KOCKS





↑ Loading and unloading a feeder vessel

THE FEEDER SERVER / POST-PANAMAX SERVER FROM KOCKS. THE CRANE SYSTEM FOR CONTAINER TRANSFER IN SMALL AND MID-SIZE TERMINALS.

A PERFECT CRANE SYSTEM
FOR CONTAINER TRANSFER
ON FEEDER VESSELS

The rapid rate of globalisation today directly influences the business in container transfer traffic. The largest container ships and correspondingly large and fast container cranes manage the growing container traffic on the world's oceans and in terminals around the globe.

Container vessels deliver their cargo to the largest terminals; from there approximately 40 percent of delivered containers are redistributed by feeder vessels along waterways to smaller ports and terminals. Vessels are frequently processed using existing large container cranes; this is not an economically ideal solution.

Larger terminal cranes are drastically oversized for smaller feeder ships. They are too big, too heavy and not mobile enough especially when transfer to feeder ships in the immediate vicinity of a larger container vessel is required.

For this, a crane system that is optimally designed for the job that meets the specific needs of a transfer operation to feeder vessels is needed. Thus, we have designed a very specific container crane: the Feeder Server / Post-Panamax Server from Kocks.

→ INFO

The Feeder Server / Post-Panamax Server is also setting new standards in:

- High transfer rates
- Absolute reliability and safety
- Economical operation

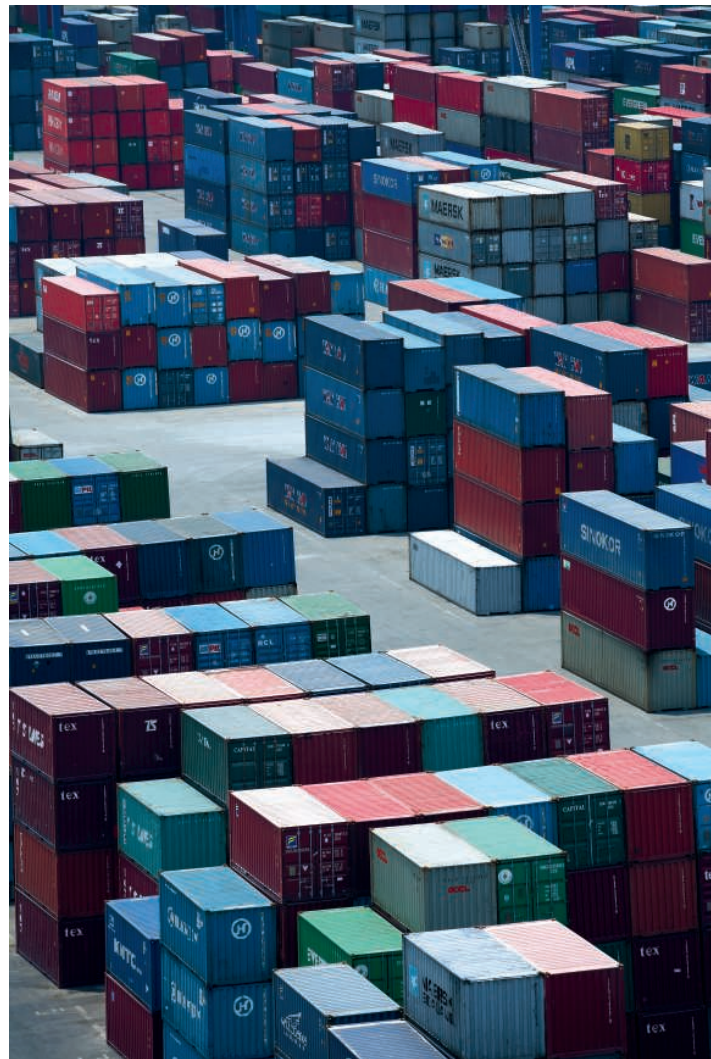

Modern container logistics require reliable cranes

MODERN GERMAN ENGINEERING: THE MODULAR, MOBILE, ECONOMICAL FEEDER SERVER / POST-PANAMAX SERVER.

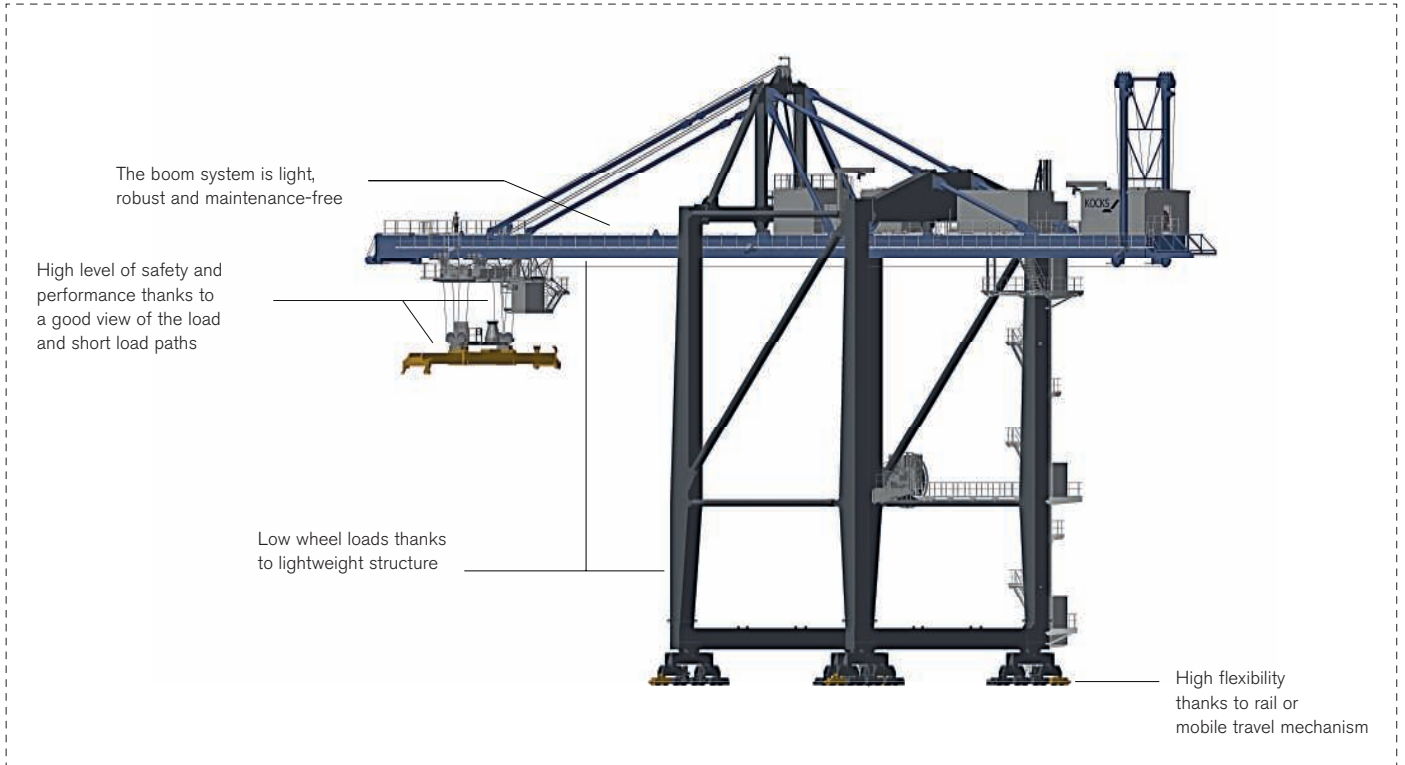

↑ Feeder Server / Post-Panamax Server: Optimal crane system for small and mid-size terminals

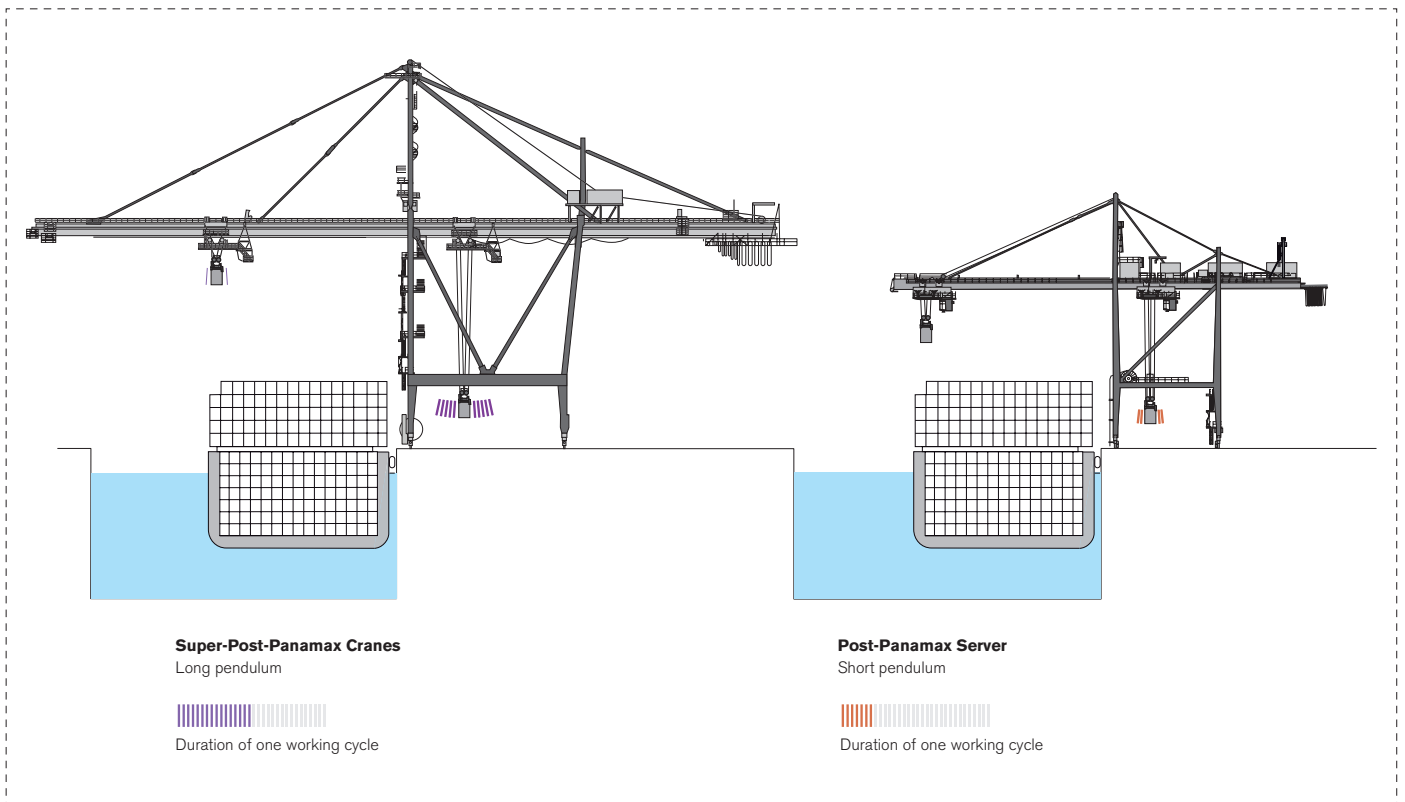

↑ Duration of working cycle comparison

HIGH TRANSFER RATE. LOW COSTS.

The Feeder Server / Post-Panamax Server is tailored precisely to the size of feeder vessels and Post-Panamax ships. A clear advantage. Low lifting heights and short ropes mean that containers can be transferred much faster. Faster than with other handling systems on the market.

Both types of container crane allow for a transfer rate of up to 40 containers per hour. The outcome of this is that numerous smaller vessels can be serviced in a short time – vessels which often only unload part of their freight and then continue on to their next destination.

This type of transfer speed is not achieved from fast movements, but from a well-conceived movement sequence. This means short travel paths as well as optimised acceleration values and speeds for the standardised design of container cranes.

The long rope lengths of larger container cranes result in lower handling rates due to the increased pendulum swing of the load and the containers are in turn harder to position. This is coupled with increased energy usage and increased costs.

The Feeder Server / Post-Panamax Server has finalised the cycle while the load on a large container crane is still swinging.



↑
Perfect harmony: Loading a feeder vessel

THERE ARE MANY REASONS TO CHOOSE THE FEEDER SERVER / POST-PANAMAX SERVER. THE MOST COMPELLING ARE:

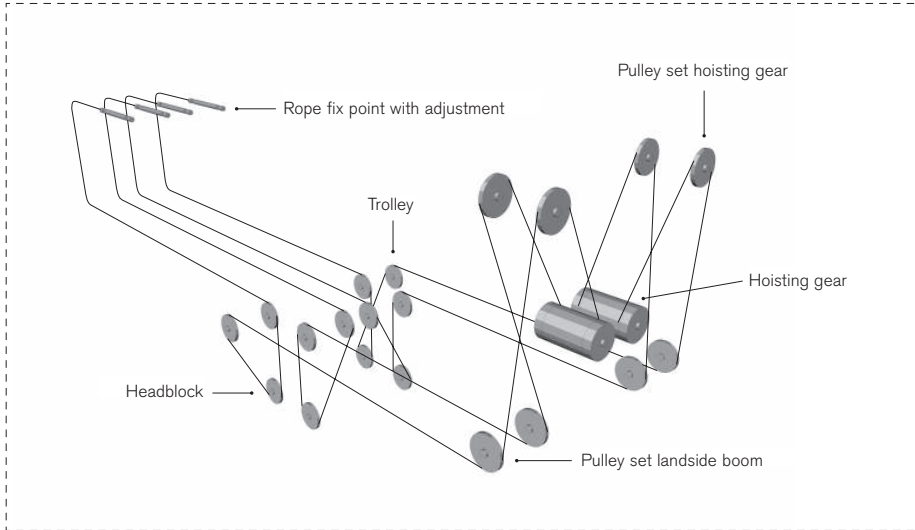

↑
Rope system of the stationary main hoist mechanism

01 THE ROPE SYSTEM

The rope system provides almost parallel rope sequences between the trolley and the spreader. This provides ideal prerequisites for the optionally available electronic anti-swing damping system.

02 THE MAIN HOIST SYSTEM / THE TROLLEY

The main hoist system is stationary and the trolley is self-driven. It is very light and can accelerate and brake precisely. The low trolley weight also reduces the weight of the structure of the Feeder Server / Post-Panamax Server.



↑
Close to the load: The Feeder Server is ideally adjusted to the size of feeder vessels



↑
The trolley of the Feeder Server Mobile



↑
The main hoist system: Compact powerhouse made from high-quality components



↑
Operator seat with CMS monitor

03 THE PORTAL

The low trolley weight results in the portal being lighter overall and thanks to its diagonal bracing, it is very sturdy with low vibration.

04 THE STRUCTURE

Both types of container crane effectively support the crane operator in his work thanks to their optimised design. The crane is lower and the driver's cabin is closer to the load. The crane operator has a better view of the ship and the quay.

05 THE CABIN

The cabin is designed to provide convenient and clear visibility. All of the controls are within easy reach of the crane operator. This helps to prevent fatigue and ensures continuously high performance.

The interaction of all of these factors results in a perfect movement sequence with the highest precision. The containers are quickly picked up and deposited precisely.

The Feeder Server can also be produced in a mobile version mounted on tyres instead of bogies and rails.

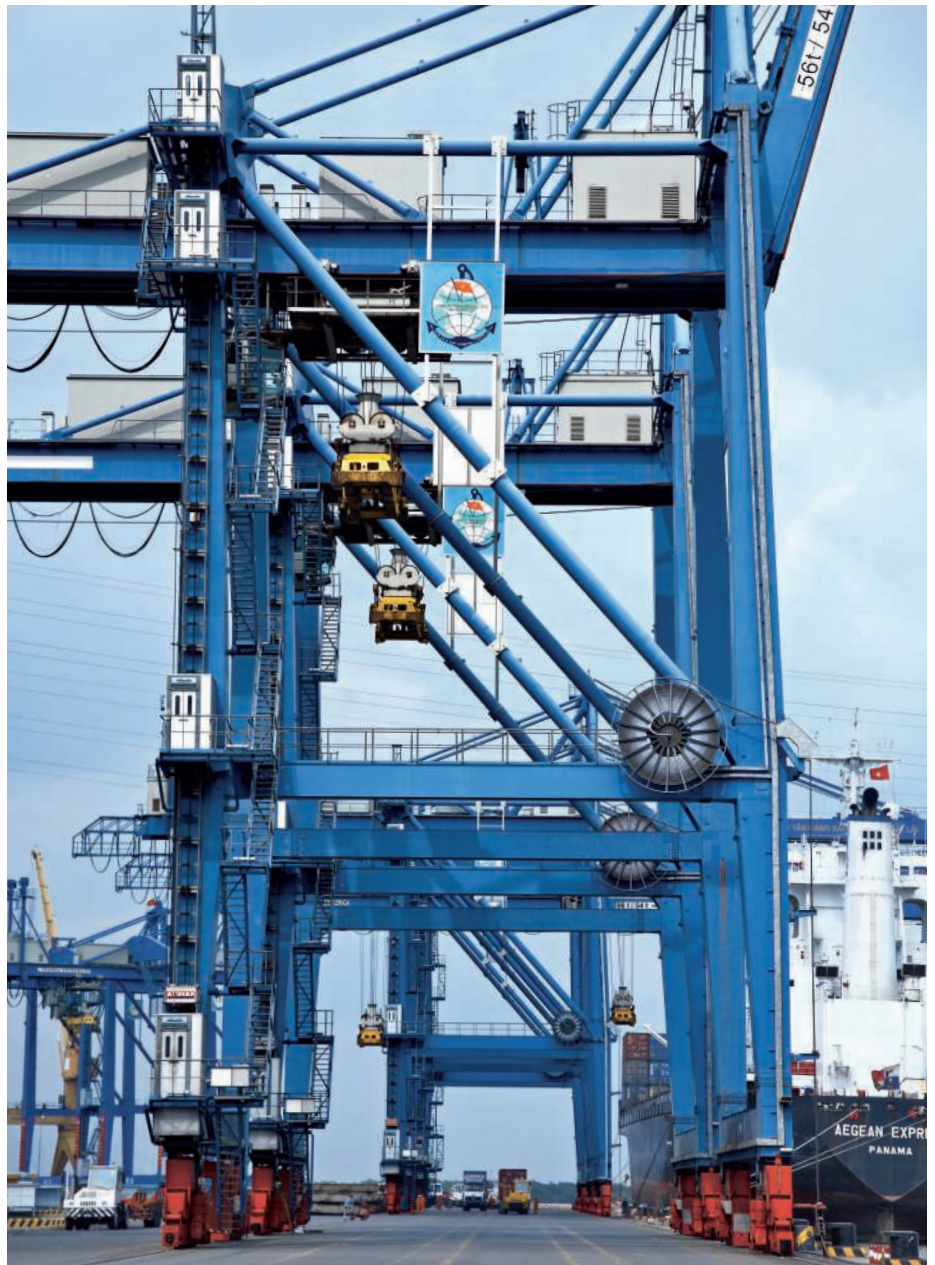

↑
The portal: Light, rigid, low-maintenance



↑ Highest performance class with the added benefit of low weight on the rails. The Feeder Server / Post-Panamax Server

ABSOLUTE RELIABILITY AND SAFETY.

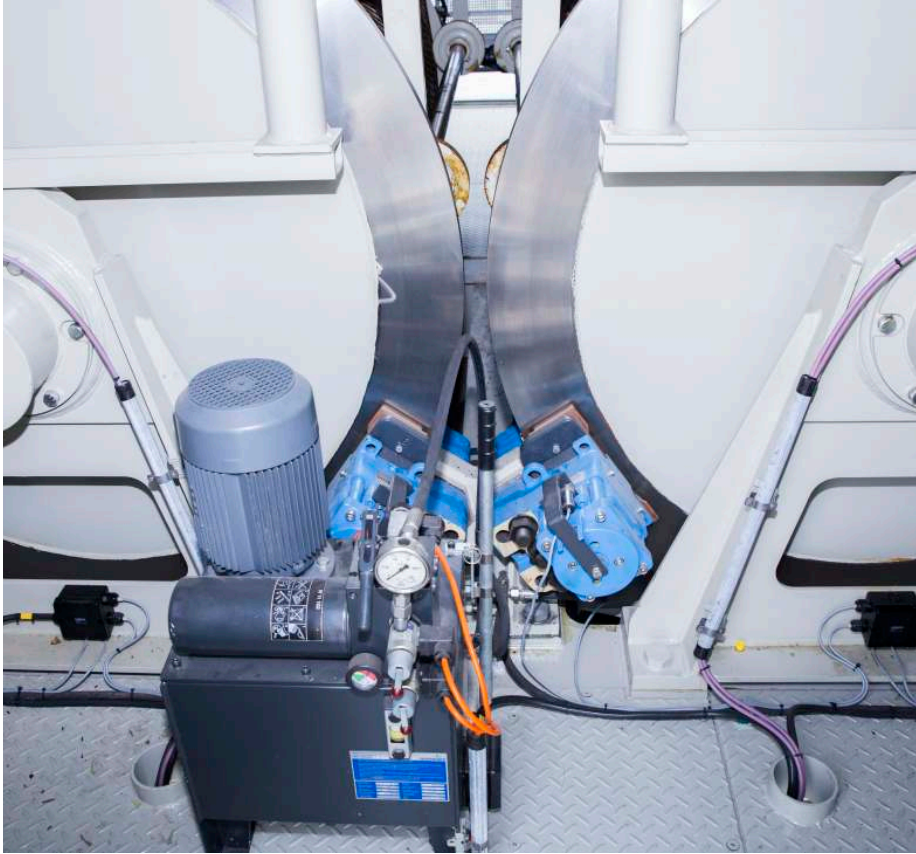

↑ Safety brakes on the lifting gear



↑ Boom hoist gear



↑ Storm locks

Both types of container crane are extraordinarily reliable. Only proven, high-quality European components are used in the crane units.

The design was conceived to be low-maintenance. This extends the maintenance intervals and the service life.

The boom hoist system can still be used with emergency drive and emergency feed in the event of a failure. An emergency drive can also be provided as an option with the main hoist system.

Safety systems in all of the drives react immediately in hazardous situations. Overload safety, over-rotation protection and overheating protection prevent failures and accidents. Snag load equipment is available as an option to increase the

safety design. This prevents the worst type of crane accident.

Safety brakes in the main and the boom hoist systems prevent load or boom drops in the event of overloading or over-rotation.

Collision protection systems prevent adjacent cranes colliding. Storm safety features prevent the crane from drifting or tipping over in the event of a storm and/or high winds.

The entire crane has very good accessibility. There is a man lift and a staircase on the portal. This allows the crane operator to reach his workstation simply and safely and also provides service points that are easily accessible. Both container cranes have convenient maintenance

stages, stairs and ladders. Maintenance cranes and auxiliary systems support the maintenance work.



↑ Collision protection systems

THE THEORY: EXTREME EFFICIENCY. THE PRACTICE: THE FEEDER SERVER / POST-PANAMAX SERVER.

A light and sturdy crane with a long service life is considered economical: the design of both container cranes allows for low wheel loads, meaning they can be used on quays with a low load capacity which are unsuitable for large STS cranes.

Modern high-performance terminals are using increasingly less and less diesel technology. With fully electrical drive motors, renewable energies can be used, making ports more environmentally friendly by lowering emissions and saving resources.

Both container cranes have fully electrically operated engines. When lowering the load and when braking the recovered energy is fed back to be used by the crane itself or fed back into the grid. This makes both types of container crane extremely environmentally friendly, energy efficient and economical.

Both types of container crane need only one-fifth of the energy that a mobile harbour crane uses. All variations have standardised engines and a standardised electrical system, which is identical on all cranes. This saves engineering costs and reduces delivery times.

The life cycle graphic shows the overall costs of both types of container crane in comparison to a mobile harbour crane. This proves that both Kocks variations are a particularly enduring investment.

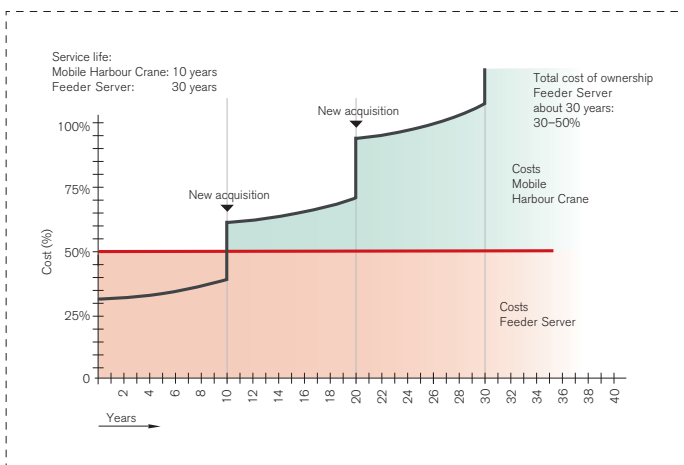

Life cycle costs

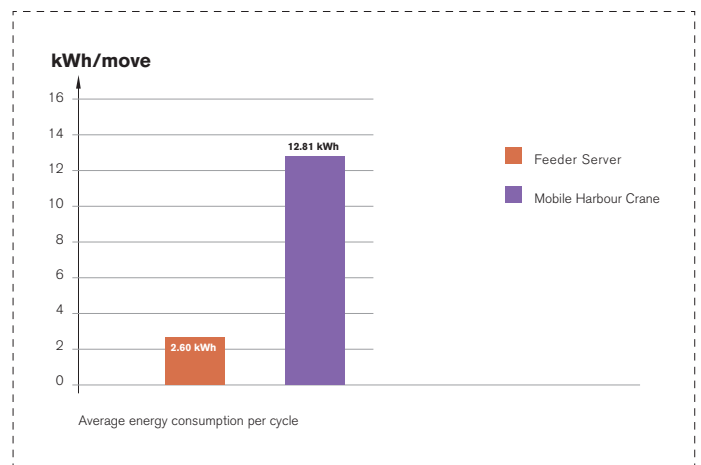

Energy consumption

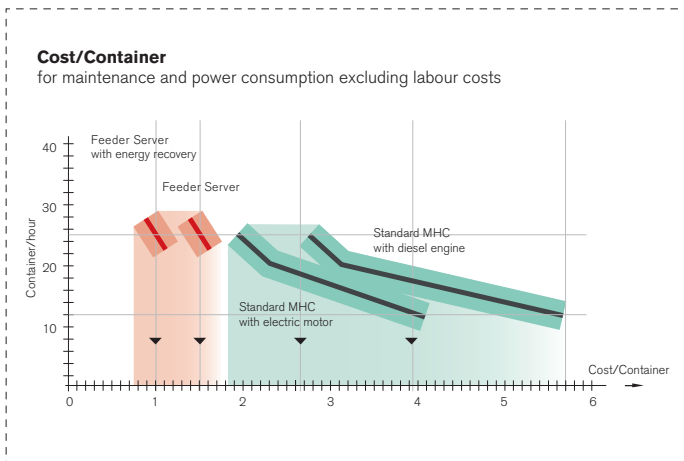

Cost per container

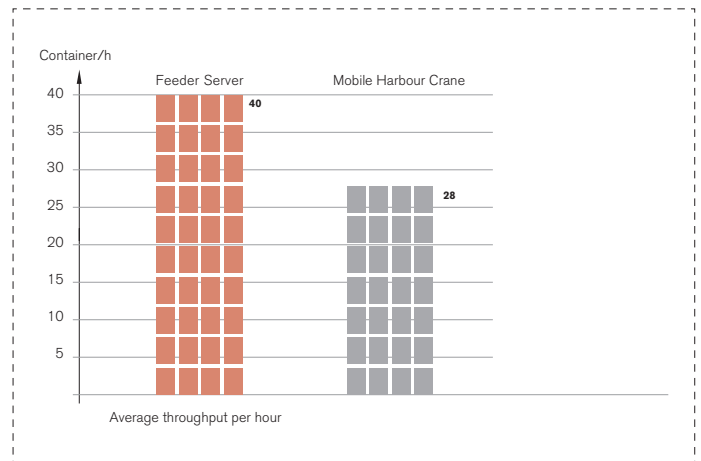

Transfer performance

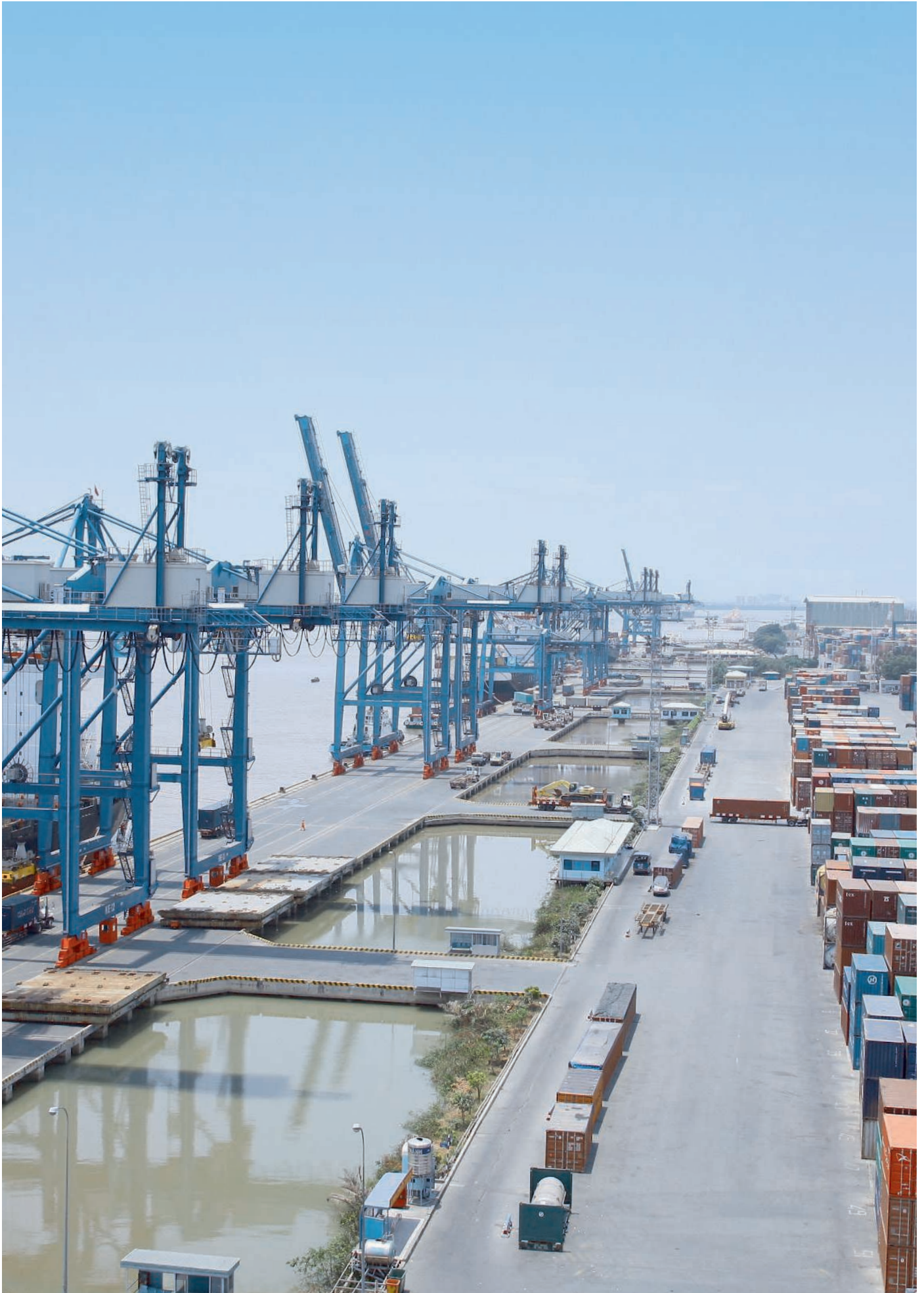

↑
The Feeder Server: The backbone of the terminal operation

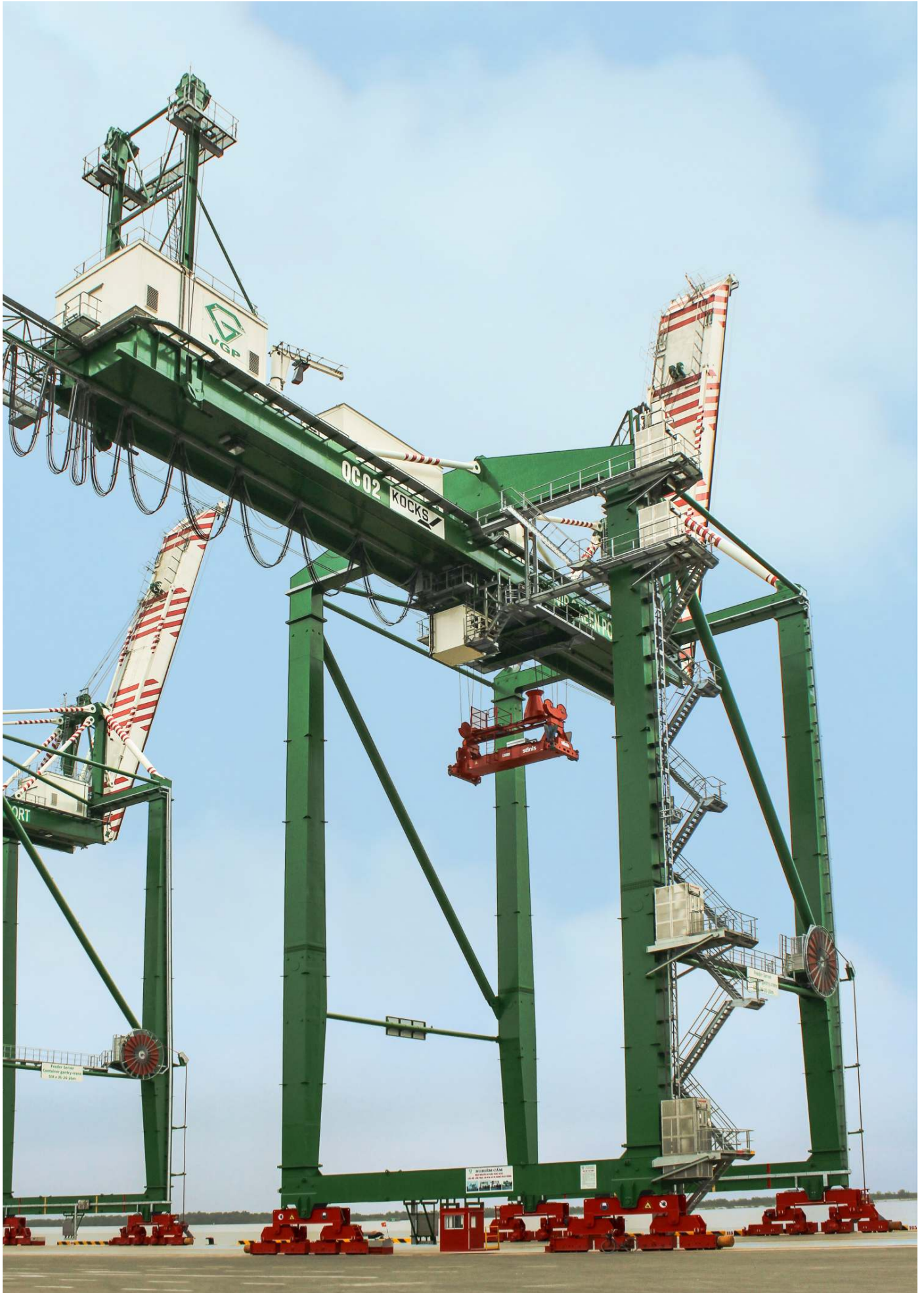

↑
Feeder Server located in Asia

WHY KOCKS?

BUILDING CRANES SINCE 1872.

→ KNOW-HOW

Kocks is considered a pioneer in the development of container cranes in Europe. Since 1913, we have been building high-performance ship unloaders and are the global leaders in shipyard crane design and manufacture. We are setting standards in high-performance cranes.

Our engineers apply the proven rules of German engineering in their ongoing development and design of cranes. The layout and classification for continuous operation is a particular area of specialist knowledge and focus.

The goal is always the same: increase the efficiency, safety and environmental friendliness of the cranes.

→ QUALITY

For us, quality means a well-conceived product concept, established know-how in the areas of design and control as well as the highest precision in manufacturing and implementation. Of course, our engineers painstakingly check and test all of the mechanical and electrical assemblies.

All of this results in decisive advantages:

- Highest crane performance capacity and reliability
- Low operating costs
- Long service life (even under the harshest of operating conditions)

→ SERVICE

Maintenance and service are part of a good product. Therefore, we provide intensive training in crane theory and practice to our customers' personnel. We want to ensure that continuous availability of the cranes is ensured.

If there should be a failure in spite of all this we help quickly, flexibly and without red tape. Day and night.

→ PARTNER APPROACH

The Feeder Server has an extremely long service life. Choosing the Feeder Server signals the beginning of a comprehensive customer/supplier relationship – which is often manifested in repeat and follow-on orders.

Thus, we place great value on this relationship and on the long-term benefits to both parties. For us, this begins long before the contract is signed. We will be happy to provide consultation; simply give us a call.



↑
Feeder Server in a Scandinavian container terminal

THE FEEDER SERVER / POST-PANAMAX SERVER – THE KEY TECHNICAL DATA.

THE FEEDER SERVER /
POST-PANAMAX SERVER
AT A GLANCE

FEEDER SERVER



- Load capacity under spreader up to 40 t (optional 45 t)
- Outreach 35–40 m
- Rail gauge 15–35 m
- Backreach 10/16 m
- Trolley travel length max. 80 m, more upon request
- Lift height above/below track 27/12 m or 30/14 m
- Main hoist nominal load / empty 50/120 m/min
- Trolley travel speed 150 m/min
- Crane travel speed 45 m/min
- Boom raise 5 min
- Transfer rate max. 40 moves/h; average > 30 moves/h
- Wheel loads max. 400 kN/wheel

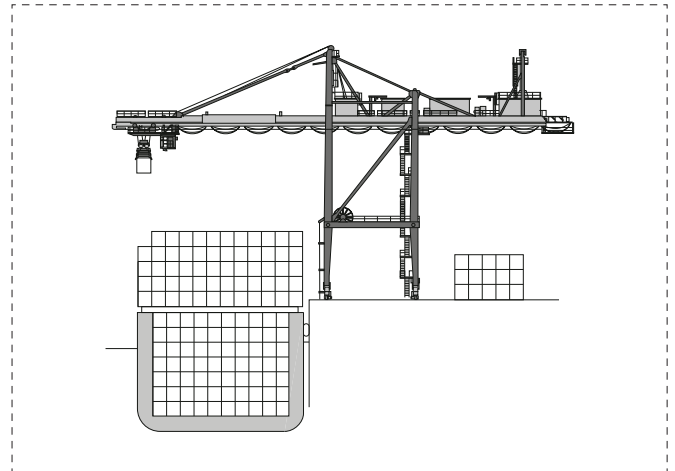

POST-PANAMAX SERVER



- Load capacity under spreader 40 t (optional 45 t)
- Outreach 45 m
- Rail gauge 18–35 m
- Backreach 5/10 m
- Trolley travel length max. 80 m, more upon request
- Lift height over/under rail 32/16 m
- Main hoist nominal load / empty 50/120 m/min
- Trolley travel speed 180 m/min
- Crane travel speed 45 m/min
- Boom raise 6 min
- Transfer rate max. 40 moves/h; average > 30 moves/h
- Wheel loads max. 450 kN/wheel

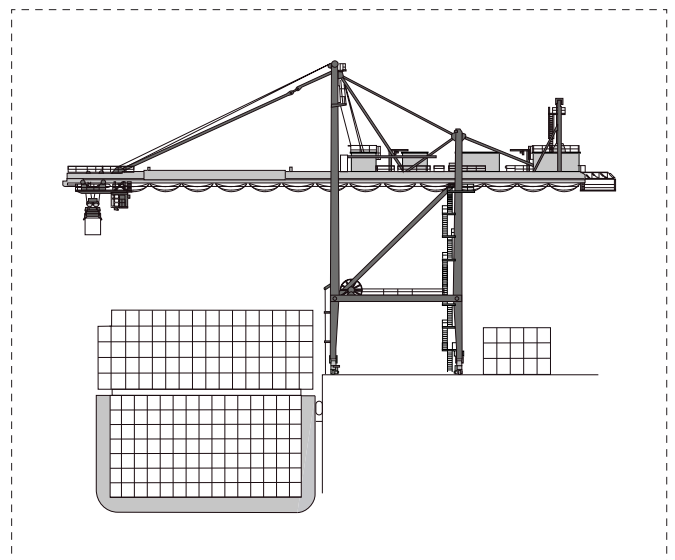



↑
Feeder vessel on the way into port: The Feeder Server guarantees the fastest service

KRANUNION. WORLD MARKET LEADERS UNITED.

Kranunion is an association of three crane manufacturers who specialise in lifting and transporting heavy loads:

KIROW is the world market leader for railway cranes and slag pot carriers

ARDELT is the world market leader for double jib level luffing cranes

KOCKS is the world market leader for Goliath cranes and a pioneer in the development of container cranes

Central to all Kranunion products are the technical design concepts created by our experts. Of course, we continue to optimise those fundamental concepts even further in the interests of our customers. Kranunion products are therefore based on practical requirements and are a symbiosis of tradition and innovation combining the tried and tested with the new.

Customers who choose Kranunion choose great German engineering skill: environmentally friendly and safe modern technology, low operating costs, and high performance and reliability.

