

BARGE SERVER YARD SERVER 40 / 60 / 70

CONTAINER TRANSHIPMENT AT INLAND PORTS
MATERIAL HANDLING IN YARDS

KOCKS





↑
Container crane with rotating spreader

THE BARGE SERVER. THE ALLROUNDER AT INLAND PORTS. THE YARD SERVER. THE ALLROUNDER AT YARDS.

Today already, the importance of inland shipping is increasing constantly. And transportation by river barge (and goods train) will become even more important – because it is considerably cheaper and more reliable than by heavy goods vehicles. Greater volumes of traffic, the incalculability of deadlines and increasing costs make onward transport of goods by road increasingly unattractive.

Inland ports, the switching points for trimodal transshipment from barge to barge, rail and road, are becoming the inland distribution hubs of the future. At the same time: in addition to the volume of container traffic, demand for general cargo and bulk goods will also continue to rise, the application area of the Yard Server.

In order to cope with these growing volumes of goods, inland ports and yards need state-of-the-art infrastructure and the corresponding crane systems, because space is a rare and expensive commodity.

In this situation, innovative, economically operating cranes are called for. Cranes that optimally exploit the precious spaces lengthwise and breadthwise. And are especially low in emissions and environmentally conscious at the same time. After all, inland ports are often located in mixed-use zones bordering on residential housing areas.

→ INFO

What characterises the best of these special cranes for inland ports and yards?
What are the key factors?

→ Essentially:

- low acquisition costs
- low operating costs
- low emissions
- high security throughout the handling process
- high handling capacity
- we are available 24/7

→ More precisely:

- efficient handling of containers, bulk goods and general cargo
- optimal storage space exploitation
- maximisation of handling capacity and thus short turnaround times of the ships
- economical unloading and loading
- low maintenance and operating costs
- long service life
- high availability and reliability
- low-noise, environmentally friendly operation
- safe operation, even in high winds

The Barge- /Yard Server combines all these features.



↑
Inland port container crane

INNOVATION AND ECONOMY FOR INLAND PORTS. **THE BARGE SERVER.** FOR YARDS: **THE YARD SERVER.**

THE TECHNICAL CONCEPT.

The Barge Server is the universal crane platform for inland shipping. The Yard Server is the universal crane platform for yards.

Its main characteristic is the weight-optimised lattice-type construction: The compression struts are arranged vertically, the tension bars diagonally. This minimises the critical length of bending, the length of the compression struts and allows the use of weight-optimised wall thicknesses. Furthermore, the struts are designed in such a way that the sawtooth appearance typical of Kocks is created: the diagonal struts each point upwards in the direction of the crane supports and thus optimally divert the shear forces into the crane structure.

In comparison to the solid structure, the lattice-type construction from Kocks is thus considerably lighter. This is particularly relevant with large span widths. For the lighter design results in lower investment costs when building the wharfage. Even existing wharfage with limited permissible loads can be equipped with more powerful cranes thanks to the lower dead weight of the Barge- / Yard Server.

The Barge- / Yard Server has another inestimable advantage: compared with double girder solid boom cranes the main girder of the Kocks lattice boom design is considerably more torsion-resistant. This results in better handling characteristics of the trolley. The compact design of the trolley frame results in improved rigidity at reduced weight – and thus in less moving load.

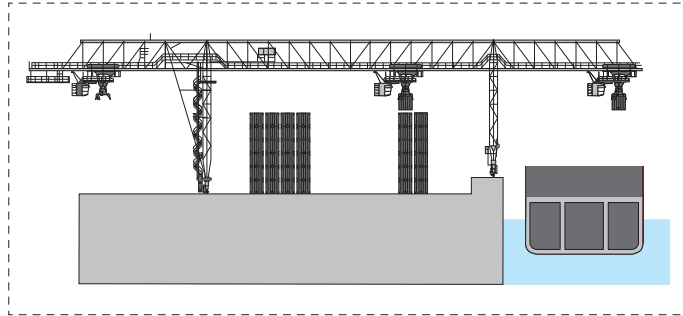

← Structure of the lattice system



← Kocks Yard Server in a yard



← Kocks Barge Server at an inland port



↑
Inclination of the gantry supports

There are also noteworthy innovations regarding the gantry supports: they are tilted approx. 15 degrees from the perpendicular and have the greatest possible width at precisely the height at which the greatest pendular movements of the load can occur: in the area where containers pass through. The support gantries weigh considerably less than comparable versions with perpendicular supports. Furthermore, because of the tilting, the gantries are more torsionally rigid and thus more resistant to oscillations in the direction of crane travel. With its broad support (solid support with tube diagonal) the Barge- / Yard Server is also considerably better armed against possible oscillations in the trolley travel direction than the solid structure without tubular diagonal).

For the transverse tie link the following applies: its low construction height

means lower lifting heights when passing through between the supports. Because of the early simultaneous movement of the hoist and trolley travel, this results in a shortening of the load paths. As a result, handling capacity is increased significantly.

Also an advantage technically is the Barge- / Yard Server's three-dimensional storage space management. This ensures optimal exploitation of the terminal. Optionally, the crane can be equipped with automatic storage space management. Furthermore: low-cost surfacing without tracks e.g. for reach stackers is also possible because the Barge- / Yard Server is capable of reaching over the entire storage space.

The Barge- / Yard Server is very economically designed and built. The comparatively lighter, open construction of

the tube lattice means there is only a small area exposed to wind – thus reducing the crane running gear capacity required. The lower crane weight resulting from this system minimises energy and investment costs right down to the foundations.

The lattice design of the Barge- / Yard Server thus results in considerable savings in a very key area: the operating costs.

→ INFO

Typical Barge- / Yard Server

- light and fast: thanks to the sawtooth structure
- extremely efficient: high handling capacity thanks to shorter load paths
- very economical: thanks to low energy consumption

THERE ARE MANY REASONS FOR CHOOSING THE **BARGE SERVER** OR **YARD SERVER**.

THE MOST COMPELLING ARE:

THE TECHNICAL HIGHLIGHTS.



↑ Electronic lifting gear monitoring

01 THE LIFTING GEAR

We have optimised our lifting gear over decades so we can guarantee maximum performance and availability. As standard they are fitted with compact, powerful drives, high-quality helical gear boxes and hoisting drums. That means savings in weight and costs. Versions with single or double lifting units are possible – depending on the application.



↑ Compact lifting gear unit

02 THE TRAVEL MECHANISM

Because we consider reliability a cardinal virtue, we only use proven components from well-known manufacturers. Characteristic of Kocks running gear is the distinctly robust design plus a speciality: being modular in design, our running gear units can be combined – as modules – on the running gear rockers. They can thus easily meet the demands resulting from differing operational locations and infrastructures.



↑ Standardised running gear

Another running gear highlight is the single wheel drive. Because the travelling speed of the Barge- / Yard Server is above average, it is advantageous to minimise wear by means of slippage.



↑ Corner bearing for rapid wheel change

Incidentally, the proprietary Kocks optimised drive and control concept needs no active synchronous run control and results in excellent straight running characteristics.

And another thing: in comparison to rubber-tyred running gear the rail-mounted Barge- / Yard Server running gear units are considerably cheaper in acquisition and in maintenance. Because the high costs of tyres is eliminated.



↑
Left side of a driver's cabin

03 THE CONTROL SYSTEM

Kocks has access to a great deal of experience and know-how developed over years in electrical engineering, programming and commissioning. For example, we have the Barge Server control system made in the state-of-the-art production facilities of our Kranunion partner Ardelt in Eberswalde.

Intelligent components and forward-looking functions are features of the Barge- / Yard Server control system: remote maintenance via modem and the crane management system with online help, for example, support preventive maintenance. They ensure smooth crane operation.

04 THE ELECTROCONTAINER

In the modularly structured electrocontainer too, we only install premium components. In the production hall in Eberswalde we populate the cabinet frames, install them completely and test them meticulously.

The Barge- / Yard Server electrocontainers thus stand out thanks to:

- their clearly arranged modular structure
- tested high quality components and functionality
- lower freight costs thanks to smaller dimensions
- less installation work during assembly.



↑ Inside the electrocontainer

05 THE DRIVER'S CABIN

Kocks driver's cabins are always custom-made on the basis of standardised designs. We design them according to customer wishes and operational conditions on location.

Ergonomic arrangement of the operating controls is understood. Equipping of the cabin with air conditioning and heating, a WLAN and camera monitoring is possible at any time.

What crane drivers especially like about the Barge- / Yard Server: from their cabin they always have the best possible overview of the entire operational area – and can position the load exactly.



↑ Crane diagnosis system in the crane cabin

06 ACCESS

We can build the ascents to the crane and trolley as a ladder, spiral stairway or stair tower. The installation of an elevator is also possible.

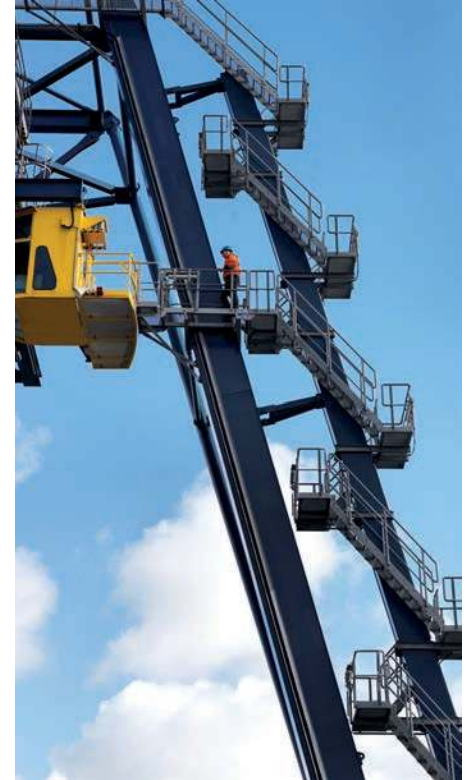

↑ Crane exit



↑ Switch racks in the air conditioned electrocontainer



↑ View from the crane driver's cabin

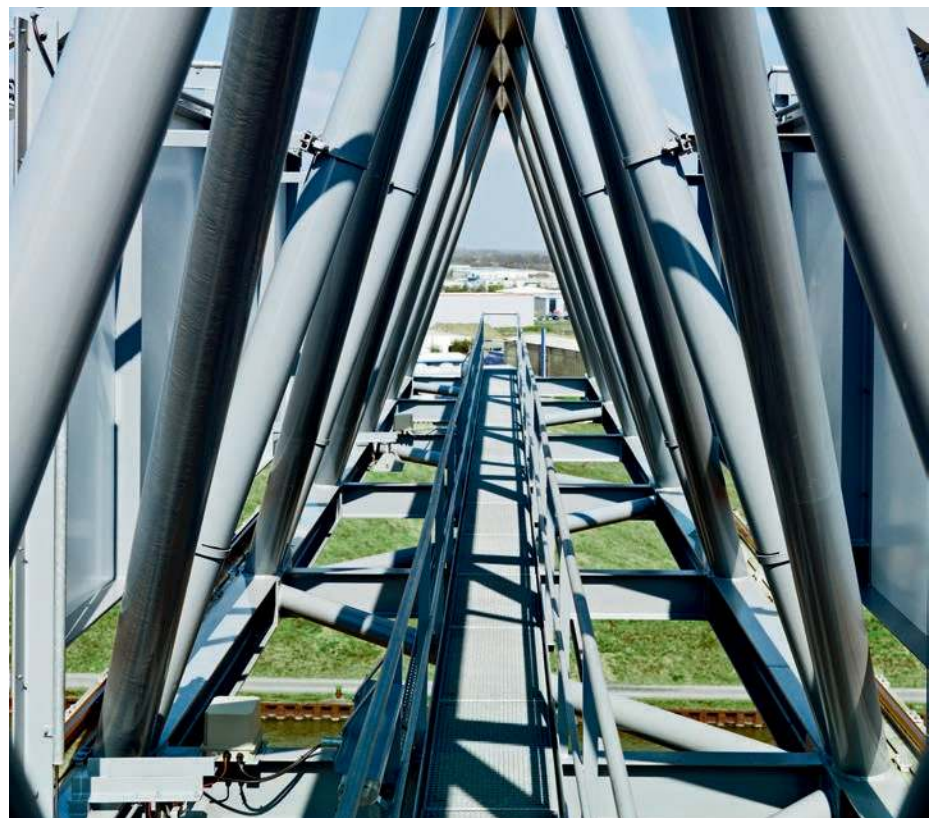

↑ Maintenance path in the crane bridge

THE THEORY: MAXIMUM HANDLING CAPACITY AND MAXIMUM RELIABILITY. THE PRACTICE: THE BARGE SERVER. THE YARD SERVER.

The Barge- Yard Server is at home wherever fast transhipment over the quay side is needed and efficient material handling on the yards is needed.

As exceedingly efficient equipment it is ideally suited for waterside container transhipment from barges onto land, from barge to barge, onto rail or road and for stocking storage areas. You can also change its load handling equipment very quickly – and then efficiently tranship general cargo and bulk goods.

Thanks to bridge lengths of up to 160 m the Barge- / Yard Server is

capable of spanning large areas and ensuring optimal exploitation of space. Because it doesn't have to keep traffic routes free e.g. for mobile cranes or reach stackers. The crane cabin, which travels with the crane, ensures excellent visibility into storage areas – the fundamental prerequisite for optimally structured terminal or storage space organisation. And thanks to state-of-the-art software, existing storage space management systems can be easily integrated too.

The Barge- / Yard Server is a multi-purpose crane in container, bulk handling, general cargo or heavy load

operation. It is the optimal, economical solution for smaller and medium-size barge terminals and yards.

What distinguishes the Barge- / Yard Server overall:

- high handling capacity
- high positioning accuracy
- high operating speeds
- high availability
- high resale value
- long service life
- low dead weight
- low maintenance effort and costs
- low operating costs

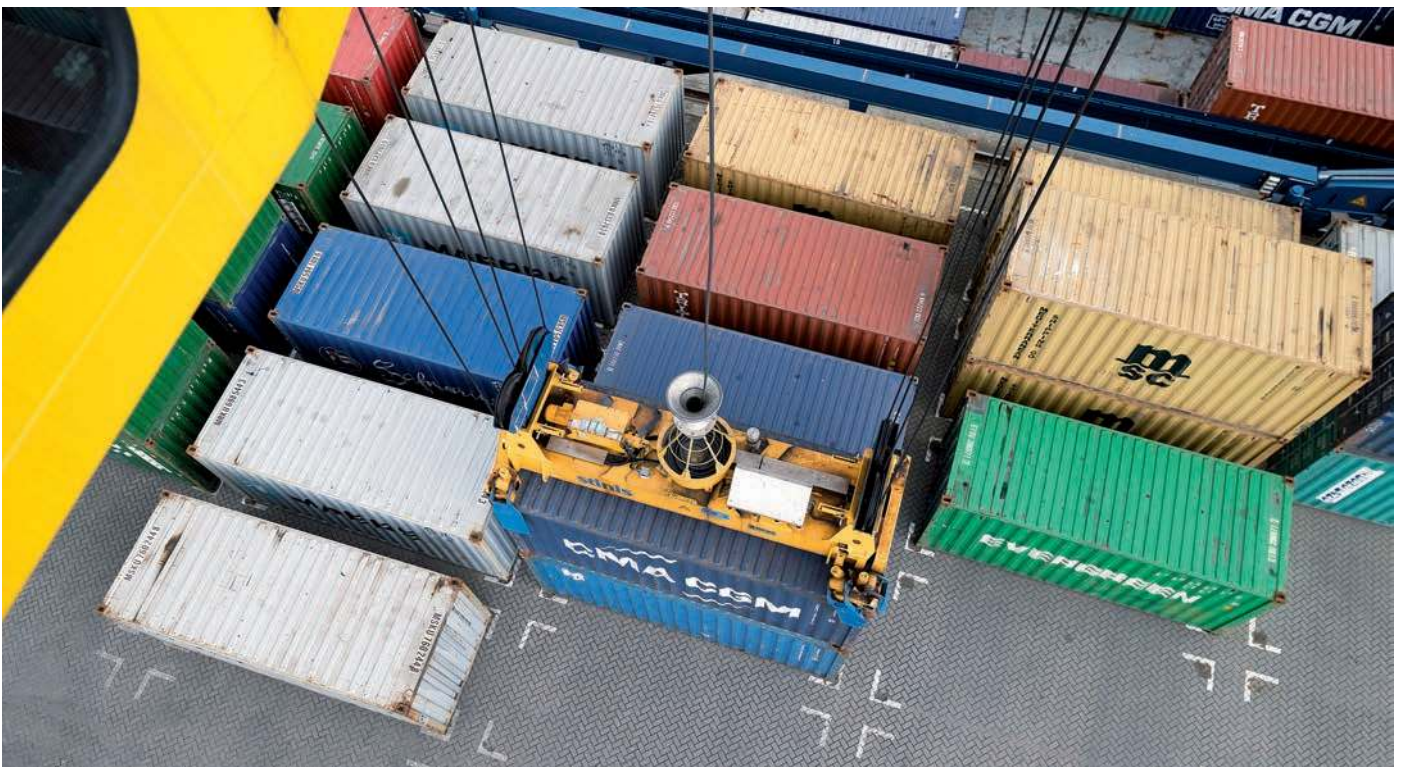

↑
High-performance cranes at a container terminal

WHY KOCKS?

CRANE CONSTRUCTION SINCE 1872.

→ KNOW HOW

Kocks has developed high-performance ship unloaders since 1913. We are considered pioneers in the development of container cranes in Europe – and we are leaders on the world market in the field of Goliath cranes. Kocks sets standards for the high performance of cranes.

Our engineers consistently apply the approved regulations of German engineering when continuously developing and designing cranes. Designing and classification for continuous operation is carried out particularly conscientiously.

The goal always remains the same: increased efficiency, safety and environmental friendliness of the cranes.

→ QUALITY

To us quality means: a sophisticated product concept, profound know-how in the fields of design and control as well as the greatest accuracy with regard to fabrication and execution. It goes without saying that our engineers test and check all mechanical and electrical components meticulously.

This provides decisive advantages:

- maximum efficiency and reliability of the cranes
- low operational costs
- long service life (even under the toughest operating conditions).

→ SERVICE

Perfect maintenance is part of a good product for us. We therefore train the personnel of our customers intensely in the fields of crane theory and crane practice. We want to assure that continuous availability of the cranes is guaranteed.

If a failure should occur in spite of everything, we assist quickly and in a flexible and unbureaucratic way. Around the clock. We are available 24/7.

→ PARTNER APPROACH

The Barge and Yard Server are extremely durable products. The decision in favour of the Barge Server means the start of a comprehensive relationship between customer and supplier, which is evident from the many repeat and follow-up orders.

We therefore attach great importance to ensuring that this relationship is fair and with long-term benefits for both sides. For us this starts long before the signing of a contract. We will be pleased to advise you, simply give us a call.



↑
Home of Kocks Crane in Bremen

THE BARGE SERVER AND THE YARD SERVER – THE ESSENTIAL TECHNICAL DATA.

AN OVERVIEW OF THE BARGE
AND YARD SERVER.

GENERAL DATA:

SPEEDS

- Lifting/lowering: 40/80 m/min
- Trolley travel: up to 180 m/min
- Crane travel: up to 120 m/min
- Span width: up to 80 m
- Cantilever arm length: up to 40 m
also with hinged boom
also for transhipment barge to barge
- Basic beam length: 50 to 160 m
- Hook travel: up to 30 m

Custom solutions are available on request.

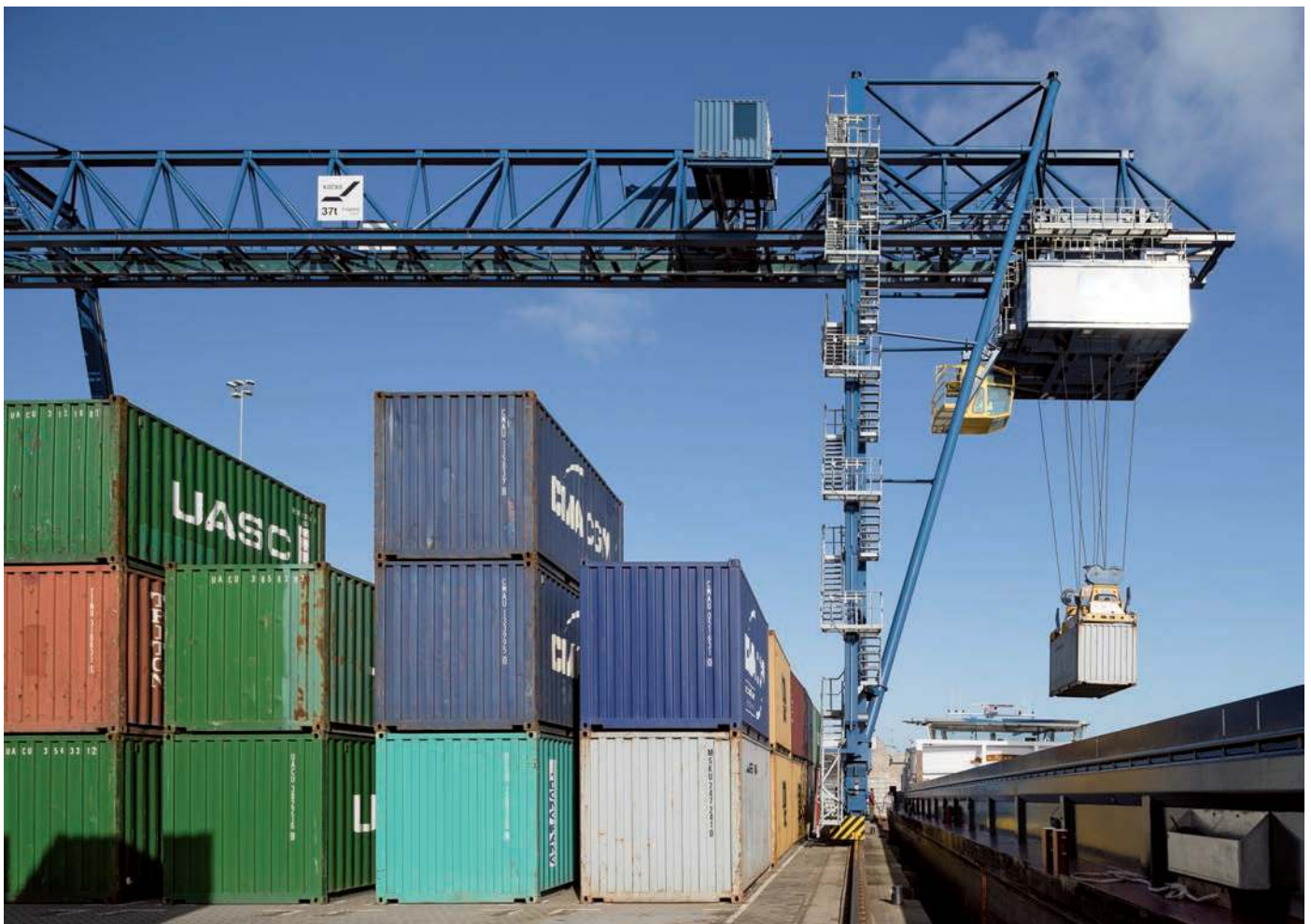

↑
Container transhipment at inland ports

THE TROLLEY CONCEPTS:

BARGE SERVER 40 / YARD SERVER 40

BEARING LOAD:

- Up to 40 t
- Wood, scrap, bulk goods grabber
- Also 4-rope grabber
- Magnet/hook
- Electronic damping of swinging motion

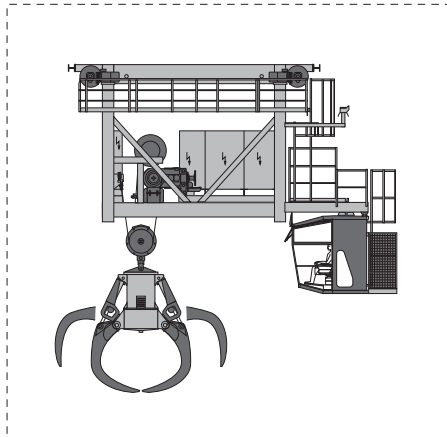

BARGE SERVER 60 / YARD SERVER 60

BEARING LOAD:

- Up to 60 t
- Containers
- Rotating spreader possible
- Wood, scrap, bulk goods grabber
- Also 4-rope grabber
- Magnet/hook
- Electronic damping of swinging motion

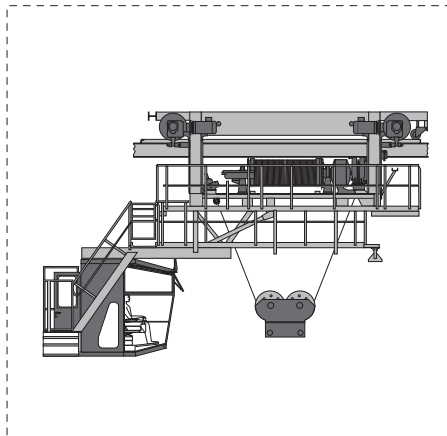

BARGE SERVER 70 / YARD SERVER 70

BEARING LOAD:

- Up to 70 t
- Containers
- Wood, scrap, bulk goods grabber
- Also 4-rope grabber
- Magnet/hook
- Damping of swinging motion by means of guying or electronic damping of swinging motion possible

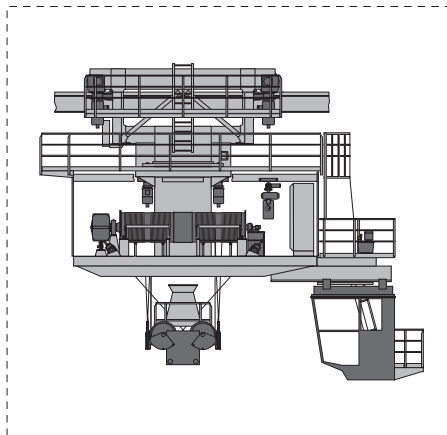

KRANUNION. WORLD MARKET LEADERS UNITED.

Kranunion is an association of three world market leaders who have specialised in lifting and transporting heavy loads:

KIROW is the world market leader for railway cranes and slag pot carriers

ARDELT is the world market leader for double jib level luffing cranes

KOCKS is the world market leader for Goliath cranes and a pioneer in the development of container cranes

Central to all Kranunion products are the technical design concepts created by our experts. Of course, we continue to optimise those fundamental concepts even further in the interests of our customers. Kranunion products are therefore based on practical requirements and are a symbiosis of tradition and innovation combining the tried and tested with the new.

Customers who choose Kranunion choose great German engineering skill: for environmentally-friendly and safe, modern technology, for low operating costs, for high performance and reliability.

